

# LINK



sweepers & scrubbers

33.LI.101 - LINK 531  
33.LI.102 - LINK 612  
33.LI.103 - LINK 722



## EN USE AND MAINTENANCE MANUAL

6/2025 Rev.00



**RCM S.p.A.**  
via Tiraboschi, 4 - 41043 Casinalbo - Modena - Italy  
Tel. +39 059 515 311 - Fax +39 059 510 783  
[www.rcm.it](http://www.rcm.it) - [info@rcm.it](mailto:info@rcm.it)



<b>CONTENTS</b>	<b>Page</b>
GENERAL INFORMATION	4
REQUESTS FOR INTERVENTION AND SPARE PARTS	4
PRELIMINARY INFORMATION	5
GENERAL SAFETY STANDARDS	6
STANDARDS TO FOLLOW DURING OPERATION	7
MAINTENANCE STANDARDS	8
PACKAGED MACHINE HANDLING	9
INSTRUCTIONS FOR MACHINE UNPACKING	9
UNPACKAGED MACHINE HANDLING	9
LIFTING THE MACHINE	9
TRANSPORTING THE MACHINE	10
TECHNICAL FEATURES	11/15
GETTING TO KNOW THE MACHINE	16/17
CONTROLS AND COMPONENTS	18/27
USING THE SCRUBBER	22
• Necessary precautions	22
STANDARDS FOR SCRUBBER COMMISSIONING	22
• Points for operating the scrubber	22
WATER LOADING AND WASHING PHASE	23
• Water loading	23
• Detergent selection	23
• Washing phase	23
"STANDARD" OPERATING MODE	24
• Turning on the machine	24
"GO GREEN" OPERATING MODE	25
"MY LINK" OPERATING MODE	25
ACCESSORY AND PARAMETER MANAGEMENT   DEALER LEVEL (ENABLED)	26/29
BATTERY DISCHARGE PERCENTAGE AND ALARM THRESHOLDS	30
END OF THE WASHING PHASE	30
WATER DRAINING AND CLEANING THE RECOVERY TANK	31
WATER DRAINING FROM THE SOLUTION TANK AND WATER FILTER CLEANING	32
• Water Draining From Solution Tank (Clean Water)	32
• Clean water filter cleaning (solution)	32
MAINTENANCE	33
• "Washing" DISC brushes (Link 531 - 612 - 722)	33
• Splash guard rubber blades (flap)	33
SQUEEGEE	34
• Assembly of the squeegee	34
• Adjustment of the squeegee	34
• Cleaning the squeegee	34
• Changing the drying edge or replacing the squeegee rubber blades	34
• Front rubber	34
• Rear rubber	34
VACUUM MOTOR	35
DRIVE SYSTEM	36
Manual handling of the machine when it is not possible to use the drive (traction)	36
STEERING	37
PUSHING AND TOWING THE MACHINE	38
BRAKING	38
ELECTRICAL SYSTEM	39/40
• Batteries	39
• Electronic control unit and dashboard (display)	39
• Installation of 6V batteries	39
• Installation of 12V batteries	39
STANDARDS FOR RECHARGING BATTERIES WITH ON-BOARD OR OFF-BOARD CHARGERS	41
"SPE CBHD3" ON-BOARD CHARGER FOR LEAD-ACID - GEL - AGM BATTERIES	42
• On-board charger "SPE CBHD3 24V 25A" (Optional)	42
Charging the batteries on-board battery charger (optional)	42
"NORDELETTRONICA NE286" ON-BOARD CHARGER FOR LEAD-ACID - GEL - AGM BATTERIES	43
• On-board charger "SPE CBHD3 24V 25A" (Optional)	43
Charging the batteries on-board battery charger (optional)	43
"SPE CBHD3" ON-BOARD CHARGER CONFIGURATION DIPSWITCH (LEAD, GEL AND AGM BATTERIES)	44
"NORDELETTRONICA NE286" ON-BOARD CHARGER CONFIGURATION DIPSWITCH (LEAD, GEL AND AGM BATTERIES)	45
ON-BOARD CHARGER ("EKT" LITHIUM BATTERIES)	46
• On-board charger "24V-30A model EKT CHBOB24V30A" (Optional)	46
Charging the batteries on-board battery charger (optional)	46
EXTERNAL CHARGER	47
CONTROL UNIT ALARMS	48
• Diagnostics of control unit alarms.	48
ELECTRICAL SYSTEM - WIRING DIAGRAM	49/51
PERIODIC CONTROL AND MAINTENANCE OPERATIONS AND SAFETY CHECKS	52
• Control and maintenance operations table	52
TROUBLESHOOTING	53/54
SAFETY INFORMATION	55
MACHINE DEMOLITION	55

## GENERAL INFORMATION

### Identification data of the machine

Summary plate of the machine type.



## REQUESTS FOR INTERVENTION AND SPARE PARTS

Any requests for assistance should be made after carefully analysing the problems and their causes, and you must indicate the following at the time of the call:

- Hours of work.
- Serial number.
- The details of the encountered defects.
- The checks carried out.
- The adjustments made and their effects.
- Alarms displayed (with electronic management).
- Any errors of use.
- Any other useful information.

Direct requests to the authorised support network.

When replacing parts, use only ORIGINAL SPARE PARTS, tested and approved by the manufacturer. Do not wait for components to become worn from use, replacing a component at the right time means better machine operation and savings, as you avoid greater damage.

## PRELIMINARY INFORMATION

The following symbols are intended to attract the reader/user's attention so that the machine is used properly and safely, more precisely they mean the following:



### **ATTENTION!**

**HIGHLIGHTS RULES OF CONDUCT TO BE OBSERVED IN ORDER TO AVOID DAMAGE TO THE MACHINE AND THE OCCURRENCE OF HAZARDOUS SITUATIONS.**



### **DANGER!**

**HIGHLIGHTS THE PRESENCE OF HAZARDS THAT CAUSE RESIDUAL RISKS TO WHICH THE OPERATOR MUST PAY ATTENTION IN ORDER TO AVOID ACCIDENTS AND/OR DAMAGE TO PROPERTY.**



### **IMPORTANT!**

- This manual must be kept carefully. It should always be available for reference. In case of damage or loss, you can request a copy by contacting your dealer or the manufacturer directly.
- We reserve the right to make changes to production, without being obligated to update previous manuals.
- Before you start working with your machine, carefully read and understand the information contained in the manual and strictly adhere to the instructions given.
- To obtain optimum efficiency and machine life, carefully follow the table indicating the periodic operations to be performed.
- We wish to thank you for choosing one of our machines and we are at your complete disposal if you have any further needs.



### **ATTENTION!**

- This machine is designed to be used solely as a scrubber. Therefore, for any use other than this intended purpose, we accept no liability for any resulting damage. The risk is fully borne by the user. In particular, it cannot be used as a tractor or to transport people.
- This machine must be used to clean pavements, flat surfaces or inclines with varying gradients.
- THE MANUFACTURER is not liable for any failure, breakdown, accidents, etc. due to a lack of knowledge (or non-application) of the requirements contained in this manual. The same applies to the execution of modifications, variations, and/or the installation of accessories that have not been authorised in advance. In particular, the MANUFACTURER declines all responsibility for damage resulting from incorrect manoeuvres or lack of maintenance. Moreover, THE MANUFACTURER is not liable for actions taken by unauthorised personnel.
- This machine is not suitable for sucking toxic and/or flammable substances, therefore it is to be classified as category U.
- The machine must only be used by trained and authorised personnel.
- Make sure that the machine remains stable when parked.
- Keep people, especially children, at a safe distance during use.
- For inspection and/or part replacement, the casing must be opened with the machine off. Make sure that:

- ▶ The motors are not running.
- ▶ The starter key has been removed (if any).
- ▶ The Batteries are disconnected (by disconnecting the plug socket 16 fig.4)

- The machine, during transport, must be secured to the vehicle.
- Batteries should only be charged in a covered and well-ventilated environment (in battery electric versions).
- Waste collected by the machine must be disposed of in compliance with the current national laws in force.



### **ATTENTION!**

**DESPITE THE CLEANING OPERATIONS OF THE TANKS DURING ASSEMBLY AND TESTING, THERE MAY STILL BE SOME PLASTIC PROCESSING RESIDUES IN THE FIRST HOURS OF MACHINE OPERATION.**

## GENERAL SAFETY STANDARDS

**CE** The machine described in this manual has been built in accordance with the EU Machinery Directive 2006/42/EC (Machinery Directive). It is the obligation of the person responsible for managing the machine to comply with EU directives and national laws in force regarding the working environment, in order to ensure the safety and health of operators. Always perform the preliminary checks before starting the machine.



### **ATTENTION!**

- **THE MACHINE SHOULD ONLY BE USED BY A QUALIFIED OPERATOR. PREVENT UNAUTHORISED PERSONS FROM USING THE MACHINE BY REMOVING THE STARTER KEY (IF FITTED).**
- **DO NOT MAKE MODIFICATIONS, CHANGES, OR APPLICATIONS ON THE MACHINE THAT COULD COMPROMISE SAFETY.**
- **BEFORE STARTING UP THE MACHINE, MAKE SURE THAT ITS OPERATION DOES NOT PUT ANYONE IN DANGER.**
- **REFRAIN FROM ANY WORKING METHOD THAT MAY COMPROMISE THE STABILITY OF THE MACHINE.**
- **WHEN TRANSPORTING THE MACHINE, MAKE SURE THAT IT IS FIRMLY FIXED TO THE VEHICLE SO THAT IT CANNOT SLIP OR TIP OVER.**
- **DURING WORK OR MAINTENANCE, IT IS MANDATORY TO WEAR APPROPRIATE PROTECTIVE EQUIPMENT SUCH AS GLOVES, GOGGLES, ETC.**



### **DANGER!**

**IN ADDITION TO THE STANDARDS LAID DOWN BY LEGISLATION, THE PERSON RESPONSIBLE FOR MACHINE MANAGEMENT MUST INSTRUCT OPERATORS ON THE FOLLOWING:**

- **THE FIXED AND/OR MOVABLE GUARDS INCLUDING THE HOUSING AND SEAT SUPPORT MUST ALWAYS REMAIN IN PLACE, PROPERLY SECURED.**
- **IF, FOR ANY REASON, SUCH PROTECTIONS ARE REMOVED, DISENGAGED OR SHORT CIRCUITED, IT IS OBLIGATORY TO RESTORE THEM BEFORE STARTING THE MACHINE.**
- **USE THE MACHINE ONLY IN TECHNICALLY PERFECT CONDITIONS AND IN ACCORDANCE WITH ITS PURPOSE.**
- **ITS INTENDED USE ALSO INCLUDES OBSERVING ALL USE AND MAINTENANCE INSTRUCTIONS, AS WELL AS THE CONDITIONS FOR INSPECTION AND MAINTENANCE.**
- **VACUUMING INFLAMMABLE AND/OR TOXIC SUBSTANCES IS STRICTLY PROHIBITED.**
- **"TOUCHING" THE MOVING PARTS OF THE MACHINE IS ABSOLUTELY PROHIBITED; SHOULD IT BE ABSOLUTELY NECESSARY, FIRST STOP MACHINE OPERATION.**
- **THE COVER MUST ONLY BE OPENED WHEN THE MOTORS ARE NOT RUNNING AND THE POWER SUPPLY HAS BEEN DISCONNECTED; FOR BATTERY-POWERED MACHINES, REMOVE THE STARTER KEY (IF FITTED) AND DISCONNECT THE BATTERY.**
- **USING THE MACHINE IN HAZARDOUS ENVIRONMENTS, IN THE PRESENCE OF TOXIC VAPOURS OR FUMES WHEN THE MACHINE IS NOT EQUIPPED WITH AN ENCLOSED CAB.**
- **CARRYING PASSENGERS IN ADDITION TO THE OPERATOR IS PROHIBITED.**

## STANDARDS TO FOLLOW DURING OPERATION



### ATTENTION!

**DO NOT LET PERSONS WHO ARE NOT INVOLVED IN THE WORK APPROACH THE MACHINE. THE MACHINE MUST ONLY BE USED BY OPERATORS AUTHORISED BY THE PERSON RESPONSIBLE FOR MACHINE MANAGEMENT AND WHO IS FAMILIAR WITH THE CONTENTS OF THIS MANUAL. THESE OPERATORS MUST BE PHYSICALLY AND MENTALLY FIT, AND NOT UNDER THE INFLUENCE OF ALCOHOL OR DRUGS OR MEDICATIONS.**

### ENSURE THAT:

- **THERE ARE NO FOREIGN OBJECTS ON THE MACHINE (TOOLS, RAGS, EQUIPMENT, ETC.).**
- **THE MACHINE, AFTER SWITCHING ON, DOES NOT EMIT STRANGE NOISES. IF IT DOES, STOP IT IMMEDIATELY AND DETERMINE THE CAUSE.**
- **ALL THE SAFETY GUARDS ARE PROPERLY CLOSED.**
- **REFRAIN FROM ANY ACTION WHICH AFFECTS OR RAISES ANY SAFETY CONCERNS.**
- **REFRAIN FROM WORKING IN ANY WAY THAT UNDERMINES THE STABILITY OF THE MACHINE, ALWAYS KEEP A SAFE DISTANCE FROM THE EDGES OF PAVEMENTS OR UNEVEN FLOORS WHERE THE MACHINE COULD FALL.**
- **DO NOT TAKE SLOPES TRANSVERSALLY AND DO NOT TURN AT EXCESSIVE SPEED, ESPECIALLY IF THE FLOOR IS NOT HORIZONTAL.**
- **DO NOT USE THE MACHINE IN DARK PLACES.**
- **BE ESPECIALLY CAREFUL WHEN APPROACHING SHELVES OR STACKED OBJECTS (RISK OF COLLAPSE IN THE EVENT OF IMPACT).**
- **WHEN WORKING IN WET MODE, REDUCE THE SPEED TO THE MINIMUM.**



### ATTENTION!

**DO NOT USE THE VACUUM SYSTEM OF THE SCRUBBER WITHOUT WATER. USING THE VACUUM WITHOUT WATER IS CONSIDERED IMPROPER USE AND VOIDS THE WARRANTY.**

## MAINTENANCE STANDARDS

When cleaning and maintaining the machine or replacing parts, always turn off the engine.

Remove the key (if provided) from the starter switch and disconnect the batteries.

Do not use naked flames, do not cause sparks and do not smoke near the batteries when charging them.



**ATTENTION!**

**FOR ANY MAINTENANCE, OVERHAUL OR REPAIR, ONLY EMPLOY SPECIALISED PERSONNEL OR CONTACT AN AUTHORISED WORKSHOP.**



**ATTENTION!**

**WHEN LEAVING THE MACHINE, REMOVE THE STARTER KEY (IF PRESENT). THE VEHICLE IS AUTOMATICALLY BRAKED BY AN ELECTRIC BRAKE LOCATED ON THE FRONT DRIVE WHEEL.**

**DO NOT PARK THE MACHINE IN PROHIBITED AREAS (IN FRONT OF DOORS, FIRE EXTINGUISHERS OR ON AN INCLINE.)**

---

## HANDLING OF PACKED MACHINE

---

The machine comes packed on a pallet.

The weight and dimensions are indicated in the TECHNICAL FEATURES section.

The forks of the truck or manual pallet truck must be positioned so that the centre of the package is approximately at the centre of the forks themselves. The package must be handled with extreme care, avoiding impact and lifting to considerable heights.

It is forbidden to stack the packs.

---

## INSTRUCTIONS FOR UNPACKING THE MACHINE

---

The unpacking of the machine must be carried out carefully and gently, removing the brackets on the wheels . The machine must then be brought to ground level using a metal or wooden ramp.

---

## HANDLING OF UNPACKED MACHINE

---

The unpacked machine must be checked and the batteries must be assembled if not already installed. Should it need to be handled after use for short distance transportation, disconnect the battery cables and remove the brushes and squeegee. For very long distance transportation, it is a good idea to repack the machine on the pallet. Please note that the machine can be pushed to move it short stretches. See also "DRIVE SYSTEM" - "Manual handling of the machine when it is not possible to use traction - "PUSHING and TOWING THE MACHINE - "BRAKING".

## TRANSPORTING THE MACHINE

Whenever the machine has to be transported, it is IMPORTANT to:

- Check that the solution (clean water) and recovery (dirty water) tanks are empty.
- Lift the brushes and the squeegee.
- Press the loading button 15 {fig.4} to lift the machine onto the transport vehicle.
- The electric brake on the front wheel automatically brakes the machine in the parking position. MAKE SURE THAT THE ELECTRIC BRAKE HAS NOT BEEN MANUALLY RELEASED. See also the sections entitled "PUSHING AND TOWING THE MACHINE" and "BRAKING".
- Secure the machine to the transport vehicle using special straps.
- Remove the brushes.
- Disassemble the squeegee.
- Disconnect the battery.
- Cover the machine if the transport vehicle is uncovered.
- Do not place any other material on top of the machine.



### ATTENTION!

WHEN LOADING THE MACHINE ONTO A VEHICLE USING RAMPS, PAY ATTENTION TO THE SLOPE AND THE CRITICAL POINT, AS SHOWN IN THE FIGURE:

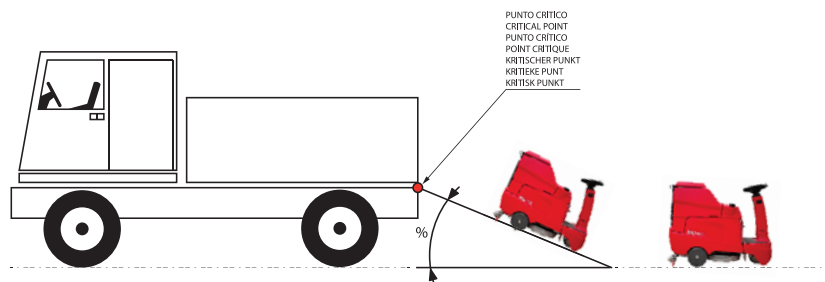

### ATTENTION!

SEE ALSO "GENERAL SAFETY STANDARDS" - DANGER OF OVERTURNING AND CRUSHING DURING THE UNLOADING/LOADING PHASES OF THE MACHINE FROM THE TRANSPORT VEHICLE.

# TECHNICAL FEATURES

<b>Versions</b>	<b>LINK 531</b>	<b>LINK 612</b>	<b>LINK 722</b>		
-----------------	-----------------	-----------------	-----------------	--	--

<b>Performance</b>					
Maximum hourly washing capacity	2385 m <sup>2</sup> /h	2745 m <sup>2</sup> /h	3285 m <sup>2</sup> /h		
Cleaning width	530 mm	610 mm	720 mm		
Drying width	745 mm	745 mm	840 mm		
Max. travel speed	5 Km/h	5 Km/h	5 Km/h		
Max. reverse speed	2.2 Km/h	2.2 Km/h	2.2 Km/h		
Max. working speed	4.5 Km/h	4.5 Km/h	4.5 Km/h		
Max. slope in no-load transfer	2%	2%	2%		
Max. slope in full-load transfer	2%	2%	2%		
Max. working slope	2%	2%	2%		

<b>Noise level [ EN ISO 11201/2010 ]</b>					
Sound pressure level in operating position	68 dB(A)	65,7 dB(A)	65,7 dB(A)		

<b>Vibrations [ EN ISO 13754/2008 ]</b>					
Level of the frequency-weighted accelerations	0.22 m/s <sup>2</sup>	0.26 m/s <sup>2</sup>	0.26 m/s <sup>2</sup>		

<b>Brushes</b>					
Brush (no./type)	1/disc	2/disc	2/disc		
"Front and rear wheel" position					
Pressure (weight)	31 Kg	36 Kg	44 Kg		
Spinning speed	140 rpm	180 rpm	180 rpm		
Lifting	electric	electric	electric		
Dimensions	Ø 530 mm	Ø 310 mm	Ø 356 mm		

<b>Waste container</b>					
Capacity	-	-	-		

<b>Squeegee</b>					
Type	floating	floating	floating		
Vacuum (squeegee vacuum)	1050 mm/H <sub>2</sub> O	13050 mm/H <sub>2</sub> O	1050 mm/H <sub>2</sub> O		
Lifting and lowering	electric	electric	electric		
Max. width of squeegee	745 mm	745 mm	845 mm		

<b>Tanks</b>					
Clean water (solution)	80 L	80 L	80 L		
Dirty water (recovery)	80 L	80 L	80 L		

<b>Steering</b>					
Mechanical with steering on front wheel	√	√	√		
Minimum U-turning radius	1870 mm	1880 mm	1880 mm		

Versions	LINK 531	LINK 612	LINK 722		
<b>Electric motors</b>					
Drive motor	n.1/24V/300W	n.1/24V/300W	n.1/24V/300W		
Brush rotation motor	n.1/24V/500W	n.2/24V/500W	n.2/24V/500W		
Vacuum motor	n.1/36V/600W	n.1/36V/600W	n.1/36V/600W		
Total installed power	1460W	1960W	1960W		
<b>Batteries</b>					
* Tubular battery (n.4, 6V-180Ah) [a]	√	√	√		
* Tubular battery (n.4, 6V-210Ah) [b]	√	√	√		
* Tubular battery (n.2, 12V-115Ah) [c]	√	√	√		
"EKT" Lithium Battery (n.1, 25.6V-90Ah) [d]	√	√	√		
"EKT" Lithium Battery (n.1, 25.6V-150Ah) [e]	√	√	√		
Operating time with tubular batteries [a]	4h 10'	3h 30'	3h 25'		
Operating time with tubular batteries [b]	4h 40'	4h 10'	4h 00'		
Operating time with tubular batteries [c]	2h 40'	2h 15'	2h 10'		
Operating time with "EKT" lithium batteries [d]	2h 25'	2h 10'	2h 00'		
Operating time with "EKT" lithium batteries [e]	4h 00'	3h 30'	3h 20'		
* Battery water	distilled	distilled	distilled		
<b>! Battery autonomy may vary, depending on the type of battery and the use of the machine.</b>					

<b>Versions</b>	<b>LINK 531</b>	<b>LINK 612</b>	<b>LINK 722</b>		
-----------------	-----------------	-----------------	-----------------	--	--

<b>Machine weight</b>					
Weight when empty, without operator, without battery	150 Kg	162 Kg	176 Kg		
Unladen weight without operator, with n.4 6V-180Ah batteries [a]	262 Kg	274 Kg	288 Kg		
Unladen weight without operator, with n.4 6V-210Ah batteries [b]	280 Kg	292 Kg	306 Kg		
Unladen weight without operator, with n.2 12V-115Ah batteries [c]	224 Kg	236 Kg	250 Kg		
Unladen weight without operator, with n.1 "EKT" 25.6V-90Ah lithium battery [d]	173 Kg	185 Kg	199 Kg		
Unladen weight without operator, with n.1 "EKT" 25.6V-150Ah lithium battery [e]	188 Kg	200 Kg	214 Kg		
Weight without operator, with full solution tank, with n.4 6V battery - 180Ah [a]	342 Kg	354 Kg	368 Kg		
Weight without operator, with full solution tank, with n.4 6V battery - 210Ah [b]	360 Kg	372 Kg	386 Kg		
Weight without operator, with full solution tank, with n.2 12V battery - 115Ah [c]	304 Kg	316 Kg	330 Kg		
Weight without operator, with full solution tank, with n.1 "EKT" 25.6V-90Ah lithium battery [d]	253 Kg	265 Kg	279 Kg		
Weight without operator, with full solution tank, with n.1 "EKT" 25.6V-150Ah lithium battery [e]	268 Kg	280 Kg	294 Kg		

<b>Traction</b>					
Front with electronic traction control for forward and reverse travel.					

<b>Wheels</b>					
Front in polyurethane	Ø 200 mm	Ø 200 mm	Ø 200 mm		
Rear in polyurethane	Ø 250 mm	Ø 250 mm	Ø 250 mm		

<b>Brakes</b>					
Electric parking brake on front wheel	√	√	√		

<b>Versions</b>	<b>LINK 531</b>	<b>LINK 612</b>	<b>LINK 722</b>		
-----------------	-----------------	-----------------	-----------------	--	--

**Machine dimensions (mm)**

**LINK 531**



**LINK 612**



**LINK 722**



<b>Packaging dimensions (pallet with cardboard)</b>					
Length x Width x Height	1894 mm	1344 mm	1702 mm		

<b>Versions</b>	<b>LINK 531</b>	<b>LINK 612</b>	<b>LINK 722</b>		
-----------------	-----------------	-----------------	-----------------	--	--

<b>Instruments</b>					
Display	√	√	√		
Brush button	√	√	√		
Brush pressure button	√	√	√		
Vacuum motor button	√	√	√		
H2O flow control button	√	√	√		
"GO GREEN" button	√	√	√		
"MY LINK" button	√	√	√		
Speed control button	√	√	√		
"ONE TOUCH" button "Brushes and Vacuum" simultaneous control	√	√	√		
Reverse button	√	√	√		
Horn button	√	√	√		
Starter switch	√	√	√		

<b>Standard accessories</b>					
Electromagnetic brake on front wheel	√	√	√		
Debris recovery tray	√	√	√		
H2O filter	√	√	√		
H2O solenoid valve	√	√	√		

<b>Accessories on request</b>					
Detersaver kit	√	√	√		
H2O Pump Kit	√	√	√		
Tubular batteries	√	√	√		
"EKT" lithium batteries	√	√	√		
On-board charger	√	√	√		
External charger	√	√	√		
Solution tank filling kit	√	√	√		
Front LED work light	√	√	√		
Emergency flashing light	√	√	√		

LED lamp [optional]

[optional]  
Water loading hose



Steering wheel /  
Control dashboard

Water/solution filling cap

Seat with microswitch

Steering column guard

Recovery tank (dirty water)

Accelerator pedal

Solution tank (clean water)

[optional]  
Work light

Rear wheels

Front wheel with electric brake

Brush base



Recovery tank cover

Starter switch



Water filter

Waste collection basket

Storage compartment

Clean water filter

Machine loading button

Solution opening, closing and dosing lever (clean water)



Plug socket for connection of electrical system and batteries

Water level tube (solution tank)

Electrical system and control unit

Vacuum motor



Footboard

**[optional]**  
On-board charger

Battery compartment and batteries

Suction hose

Dirty water drain hose

Clean water drain plug (clean water tank)

Clean water level sensor



Squeegee

## 1. Steering wheel

Controls the machine's direction of travel.

## 2. Control dashboard

The machine control buttons and information display are located on the dashboard.

## 3. Display

When the machine is switched on, display 3 will temporarily show the following information screens:



### Screen 3a:

RCM Logo / Machine model

3a



### Screen 3b:

Battery type

Hourmeter

**FW versions (Firmware electronic board on the steering wheel | power electronic board)**

3b

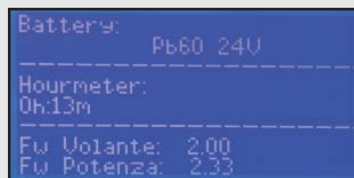

### Screen 3c:

The machine is on;

Water supply level symbol [A] (**! active only with optional Water Pump**)

Detergent dispensing level symbol [B] (**! active only with optional Detersaver**)

Battery charge level symbol [C]

Set speed level symbol [D]

3c

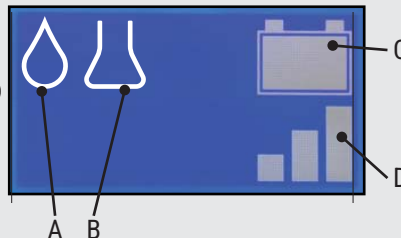

## 7. Brushes / vacuum / squeegee simultaneous command button

This controls the simultaneous activation of the brushes/vacuum and squeegee.

## 8. Water flow setting button

The function has five settable levels. Press the button to set the water flow % on the washing brushes "from 0% to the maximum programmed value". The setting will be shown on the display.

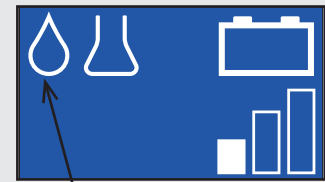

Indicates the level of water flow regulation on the brushes.  
The adjustment has 5 settable levels.

## 9. "DETERSAVER" button [optional]

The function has three settable levels. Press the button to adjust the detergent %, from "0% to the maximum programmed value". The setting will be shown on the display.

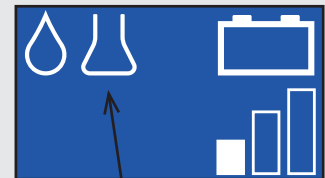

Detersaver "Option". This indicates the percentage of detergent on the brushes.  
The adjustment has 3 settable levels.

## 4. Horn command button

This controls the horn.

## 5. Brush / solenoid valve and water pump button (optional)

This controls the activation, lowering and rotation of the brushes, the solenoid valve and the water pump (optional) with settable levels from 1 to 5.

Depending on the type of machine and brushes, the function will be shown on the display.

## 6. Vacuum / squeegee button

This controls the activation, the lowering of the squeegee and recovery water suction. The function will be shown on the display.

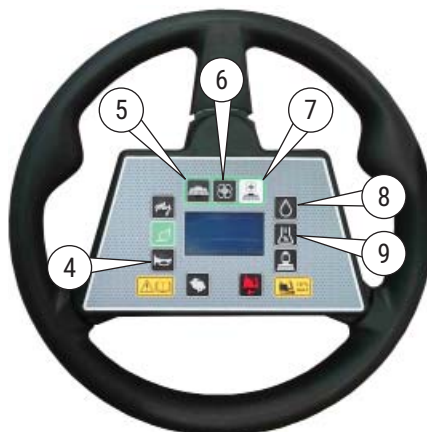

## 10. -

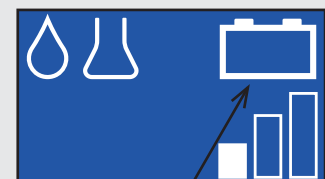

The battery symbol indicates the battery charge level.  
(See section "ELECTRICAL SYSTEM (FIG.18)".

### 11. Button to activate reverse drive

The speed is halved compared to forward drive. As long as reverse drive is running, a horn sounds. During reversing, the squeegee automatically lifts to avoid damage. The function will be shown on the display. see "STANDARD" OPERATING MODE.

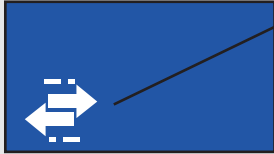

### 14. "MY-LINK" mode button

This function allows you to establish and set the operating parameters relating to the amount of water, detergent (only with Detersaver) (See chapter MY-LINK OPERATING MODE"). The function will be shown on the display.

(\* ) = UPON MACHINE START-UP WITH THE KEY, THESE ADJUSTMENTS ARE PLACED ON THE PREVIOUSLY-SET VALUES.



Indicates the "MY-LINK" mode

### 12. Speed setting button (\*)

The machine's forward drive can be set on three speeds, selectable from the keyboard. The setting will be shown on the display.

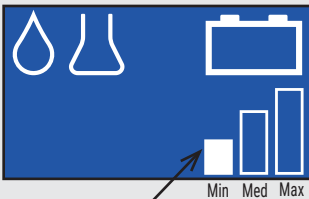

The symbol indicates the set working speed or the machine's travel speed. The adjustment includes 3 levels (min./med./max.)



### 15. Machine loading button

This is used to load the machine on the transport vehicle. Pressing the button activates reverse drive (see "Transporting the machine").

### 13. "GO GREEN" mode button

Pressing the button will activate and automatically adjust all functions, brushes, vacuum (See the "GO GREEN" OPERATING MODE chapter). The function will be shown on the display.



Indicates the "GO GREEN" mode

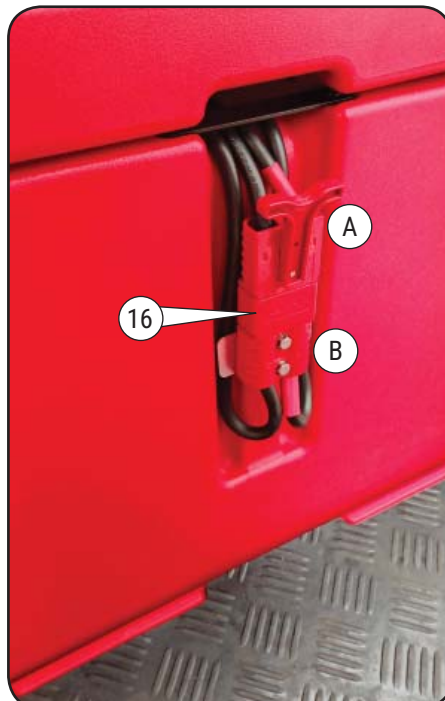

### 16 Power socket and plug for electrical system and batteries

Used to connect the electrical system and batteries.

**!** Attention!

in case of immediate need, disconnect the plug (A) from the socket (B), to stop the machine and all its functions. To restore operation of the machine and all its functionality, reconnect plug (A) to socket (B).

### 17. Recovery tank (dirty water)

Contains the dirty water which, from the washing brushes, is vacuumed up by the squeegee. At the end of each wash, drain the dirty water from the tank and clean it (see "WATER DRAINING AND CLEANING THE RECOVERY TANK").

### 18. Solution tank and solution infeed cap (Clean water)

At every wash, open cap "18a" to fill or top-up the tank with clean water and detergent.

### 19. Clean water maximum level pipe

This indicates the maximum level of the clean water in the solution tank.

### 20. Accelerator pedal

This commands the forward and reverse drive speed of the machine.

### 21. Seat with safety microswitch

Seat with safety microswitch located in zone "21b". The microswitch does not allow any machine function if the operator is not properly seated.

#### ! ATTENTION!

IF THE OPERATOR IS NOT PROPERLY SEATED AND PRESSES THE ACCELERATOR PEDAL 20, THE MACHINE DOES NOT MOVE, THE DISPLAY WILL SHOW THE FOLLOWING SYMBOL:

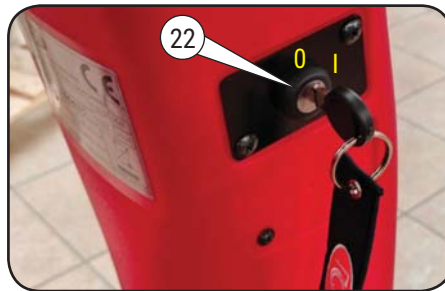
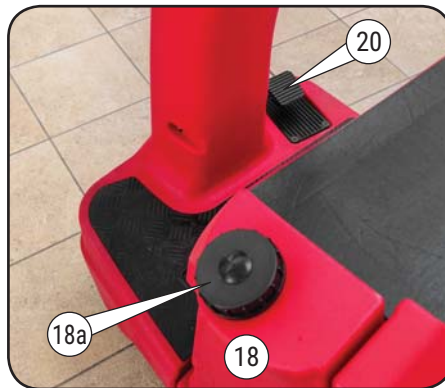
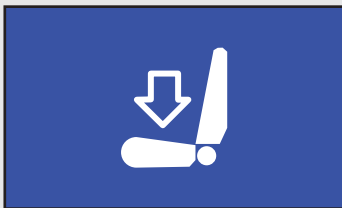

### 22. Main key switch

This turns the general system on and off

- Pos. 0 = system disconnected
- Pos. 1 = system engaged

### 23. Brush base

The LINK scrubber-dryer features 3 types of brush bases:

- Single-brush base (23a) mounted on Link 531 model
- Dual-brush base (23b) mounted on Link 612 and 722 models

The brushes mounted on the base are used for floor cleaning. (see "MAINTENANCE {FIG.12}).

### 24. Squeegee

The squeegee vacuums up the dirty water coming from the brushes. (see "MAINTENANCE {FIG.12})

### 25. Prepared for Work beacon [Optional]

If a work beacon is installed on the scrubber-dryer, it switches on automatically when the machine is powered on.

### 26. Dirty water drain hose

The pipe is used to drain the dirty water from the recovery tank. For thorough cleaning of the recovery tank, see "WATER DRAINING AND CLEANING THE RECOVERY TANK".



## 27. LED Lamp [Optional]

If the lamp and LED are installed on the scrubber-dryer, it is activated automatically when the machine is switched on.

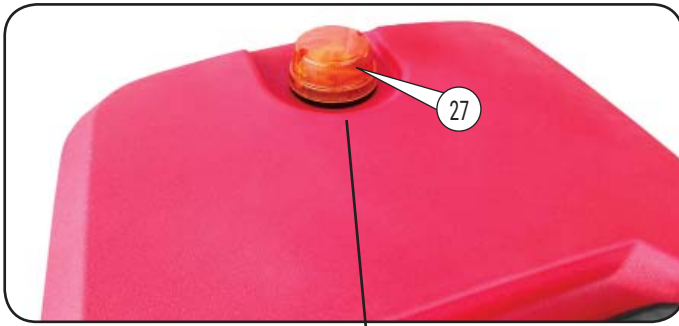

## 28. Clean water tank warning light (empty)

The activation of the warning light indicates that the clean water tank is empty, the tank should be replenished. With the activation of the warning light, the functions of "Brushes and Water flow" are disabled.

The functions "TRACTION AND ASPIRATION" remain active.

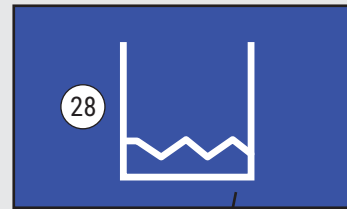

## USING THE SCRUBBER

### Necessary precautions

- THE SCRUBBER MUST ONLY BE USED BY COMPETENT AND SKILLED AUTHORISED PERSONNEL.
- WHEN LEAVING THE SCRUBBER-DRYER UNATTENDED, IT IS NECESSARY TO REMOVE THE KEY OF THE SWITCH 22 {FIG.4}, THE BRAKING IS ASSISTED BY THE ELECTRIC BRAKE PLACED ON THE FRONT WHEEL. THE BRAKE KEEPS THE MACHINE BRAKED WHEN IT IS SWITCHED OFF OR WHEN IT IS SWITCHED ON WITH THE TRACTION INACTIVE.
- DO NOT PARK IN RESTRICTED AREAS, IN FRONT OF DOORS, FIRE EXTINGUISHERS, ON INCLINES, ETC.
- WHEN THE SCRUBBER-DRYER IS AT REST, LIFT THE SQUEEGEE AND BRUSHES TO PREVENT DEFORMATION OF THE RUBBERS AND BRISTLES.
- DO NOT STOP THE MACHINE ON AN INCLINE.
- DO NOT USE THE MACHINE ON UNEVEN OR SLIPPERY SURFACES OR GRILLED FLOOR OR IN THE VICINITY OF UNPROTECTED GRADIENTS WHERE THERE IS A RISK OF OVERTURNING.
- CARRYING PASSENGERS IN ADDITION TO THE DRIVER IS PROHIBITED.
- USING THE MACHINE IN HAZARDOUS ENVIRONMENTS WITH THE PRESENCE OF TOXIC VAPOURS OR FUMES ETC. IS PROHIBITED, SINCE THE MACHINE IS NOT EQUIPPED WITH AN ENCLOSED CAB.
- USE EXTREME CAUTION WHEN APPROACHING SHELVING OR STACKED OBJECTS.



#### ATTENTION!

**IN AREAS WITH AN AMBIENT TEMPERATURE ABOVE 43°C, THE MACHINE SHOULD NOT BE USED.**

**IN AREAS WITH AN AMBIENT TEMPERATURE BELOW THE FREEZING THRESHOLD OF 0°, THE WASHING AND SUCTION FUNCTIONS MUST NOT BE USED.**

**CHECK THAT THE RECOVERY AND SOLUTION WATER TANKS ARE EMPTY.**



#### ATTENTION!

**BEFORE USING THE SCRUBBER-DRYER, CHECK THE LIQUID LEVEL IN THE BATTERY.**

## STANDARDS FOR SCRUBBER COMMISSIONING

### Points for operating the scrubber-dryer

- Make sure the recovery water tank is empty.
- Fill the tank with clean water.
- Insert the ignition key into the main panel and turn it clockwise, this operation will power the general control equipment.

Pos. 0 = Machine off

Pos. I = Machine on

Proceed as described in the chapter "STANDARD" OPERATING MODE.



#### ATTENTION!

**THE SCRUBBER-DRYER ONLY WORKS IF THE OPERATOR IS PROPERLY SEATED IN THE DRIVER'S SEAT.**

## Water loading

Before each wash, fill solution tank 1 with the right amount of water\* (\*Maximum water temperature 50°C) and detergent by opening cap 2.

The tank is built in polyethylene, which is resistant to acid and alkali products as well as most solvents.

## Detergent selection

To clean the floor well, it is necessary to find the right detergent. Use low hazard detergents, wash your hands after handling them. Refer to the instructions contained in the safety data sheets of the detergent. If necessary, seek advice from the supplier or a competent person, bearing in mind that a detergent that is too harsh can be harmful for the service life of the machine.

It is necessary to use low foam detergent, or anti-foam additive to prevent damage to the vacuum motor. If you cannot find such products, to avoid foam, you can use ordinary wine vinegar, pouring 50cc into the solution tank before washing.



### ATTENTION!

**THE WATER MUST BE LOADED AND THE DETERGENT CHOSEN WITH THE MACHINE OFF AND THE IGNITION KEY REMOVED.**

## Washing phase

Washing with your scrubber-dryer is very simple, and your experience will help you improve the work by helping in the choice of brushes, detergent, in assessing the need for a double cleaning action, etc.

With an extremely dirty or stubborn floor, it is advisable to use the double cleaning action which consists of a first wipe over a few dozen square metres of floor using only the brushes and with the squeegee raised, in this way the cleaning solution remains on the floor to dissolve the dirt, then, with the second wipe, with the squeegee lowered, the removed dirt will be collected.



### DANGER!

**THIS TYPE OF OPERATION MUST BE CARRIED OUT AT REDUCED SPEED IN AREAS WHERE ACCESS IS PROHIBITED TO UNAUTHORISED PERSONNEL. THESE AREAS SHOULD BE CLEARLY MARKED WITH APPROPRIATE SIGNS.**

To carry out the washing operation, sit correctly in the driver's seat 3, insert the ignition key 4 and choose the working mode described in the "STANDARD OPERATING MODE" or "GO GREEN OPERATING MODE" or "MY LINK OPERATING MODE" section - can only be activated with a password (**Contact Support Service**).



## Switching on the machine

When the electrical system is switched on by means of the ignition key 22 {fig.4} in pos.1, the display will show the logo, the model, then the software version, the type of battery, the hour counter and the screen relating to the status of the system with the battery charge, the various active functions and their settings and any alarms and speed.

After the above sequence has finished, the display will show the status of the clean water tank (solution). If it is empty,  will appear. It needs filling.

Before carrying out the washing operation, proceed as follows:

- Start rotation and lowering of the brushes using button "1".

Open and adjust the washing water:

- Press button "3" to activate the function and adjust the washing water flow on the brushes. The function provides for the adjustment of the flow from fully closed to fully open.

The water adjustment thus set will be automatically maintained.

We recommend using an intermediate amount of water so that the entire surface immediately behind the brushes is fully wet, without an excess of water creating spray, trickling or overflowing of the squeegee.

- Engage the vacuum motors using button "4".

The squeegee automatically lowers to vacuum up the water.

Button "6" (ONE TOUCH) is provided to simplify the activation of the brushes, vacuum and squeegee, which simultaneously controls the functions.

- Press the forward pedal 20 {fig.4} so that the machine advances at the desired speed and direction, starting the washing operation.

Check the correct adjustment of the squeegee.

**! ATTENTION! THE SQUEEGEE ONLY LOWERS WITH THE MACHINE IN FORWARD DRIVE.**

If, during the operating phase, it is necessary to proceed in reverse drive, change the machine's direction of travel by pressing button "5", in this way the squeegee will be automatically raised.

Reverse drive is shown on the display by the symbol .

When washing and drying is finished, proceed as follows:

Stop brush rotation by pressing button "1". The brushes lift automatically, the water flow is interrupted.

Stop the vacuum by pressing button "4". The squeegee lifts automatically.

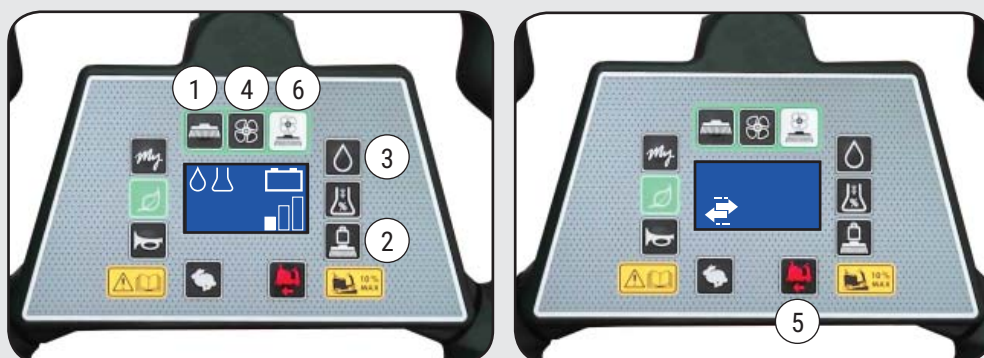

**(\*)NOTE!  
PRESS BUTTON 6 TO SIMULTANEOUSLY ACTIVATE/DEACTIVATE THE BRUSHES, THE VACUUM, THE LIFTING AND LOWERING OF THE SQUEEGEE.**



## "GO GREEN" OPERATING MODE

FIG.7

This mode allows you to reduce water, detergent and energy consumption.

To activate the "GO GREEN" mode, simply press the button , the operator will be able to immediately perform the washing phase without making adjustments to functions such as brushes, water flow opening, suction or floor cleaning. Said functions are regulated automatically by activating this mode. The function is shown on the display with the symbol.



To switch from "GO GREEN" operating mode to "standard" mode and vice versa, press  for about 2/3 seconds. The display shows the symbols, brushes and vacuum as in "STANDARD" mode .

To deactivate "GO GREEN" operating mode, press the button .

## "MY LINK" OPERATING MODE

FIG.8



With this mode it is possible to establish and set the operating parameters relating to the amount of water, detergent (only with "Deter-saver" or "Water Pump" function - optional).



To activate "MY LINK" mode, press . The operator will immediately be able to carry out the washing phase using the configuration pre-set by the manufacturer or "qualified and authorised" dealer or the operator himself can create a custom one (if enabled) to fit his needs. There are two setting management levels on the electronic control, protected by a password.

To access the parameter edit program (qualified operators and dealers), proceed as follows:

With the machine off, press buttons "1" and "2" simultaneously   then turn the ignition key "3" from 0 to I.

To manage the programming on the electronic control, some commands have a dual function as shown in the image:

Enter the password using button "4"  to increase the value or button "5"  to decrease the value. After entering the password, confirm by pressing .



Press  to scroll the parameters to be set. Each parameter will be shown on the display. Set its value using the buttons " INCREASE+  DECREASE" .

After setting the parameters, the display will show the word "MY" (standard is set to OFF).

Confirming "Fixed" = only activates "MY" mode.

Confirming "ON" = activates "MY" mode and STANDARD mode.

Press button "6"  to confirm the set value and exit programming. Turn the machine off and on again.

To switch from "MY" operating mode to "standard" mode, press  for about 2/3 seconds. The display shows the symbols, brushes and vacuum as in "standard" mode .

To reactivate "MY" operating mode, press button .

To deactivate "MY" operating mode, press button .

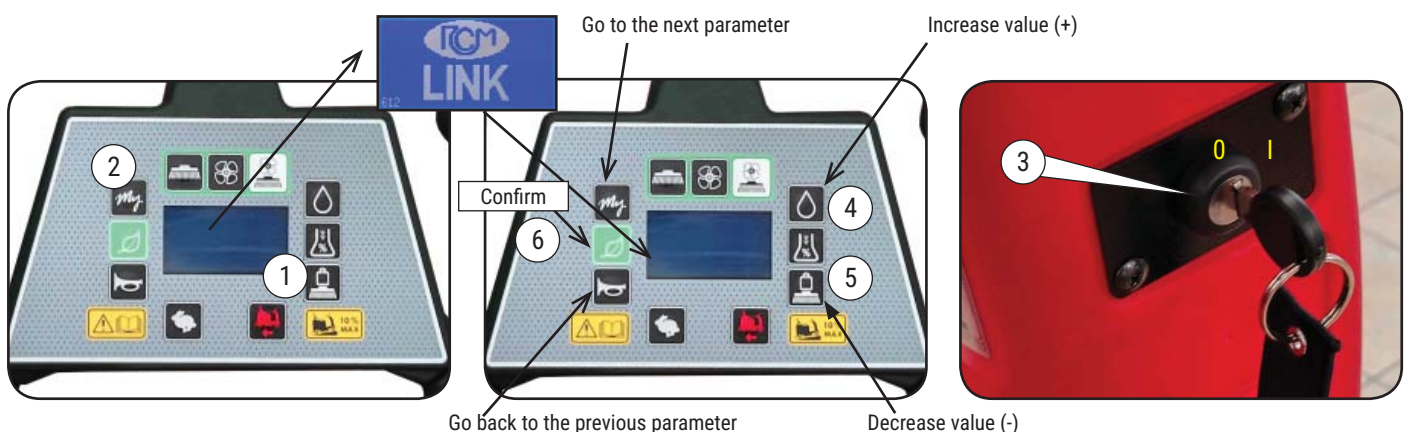

# ACCESSORY AND PARAMETER MANAGEMENT - DEALER LEVEL (ENABLED)

FIG.9

The following Tables show the main settings, to access and change the settings, press the buttons "1" and "2" simultaneously and turn the starter key "3" from pos. "0" to "I".

Enter the dealer password following the procedure described in the chapter "MY LINK" OPERATING MODE.

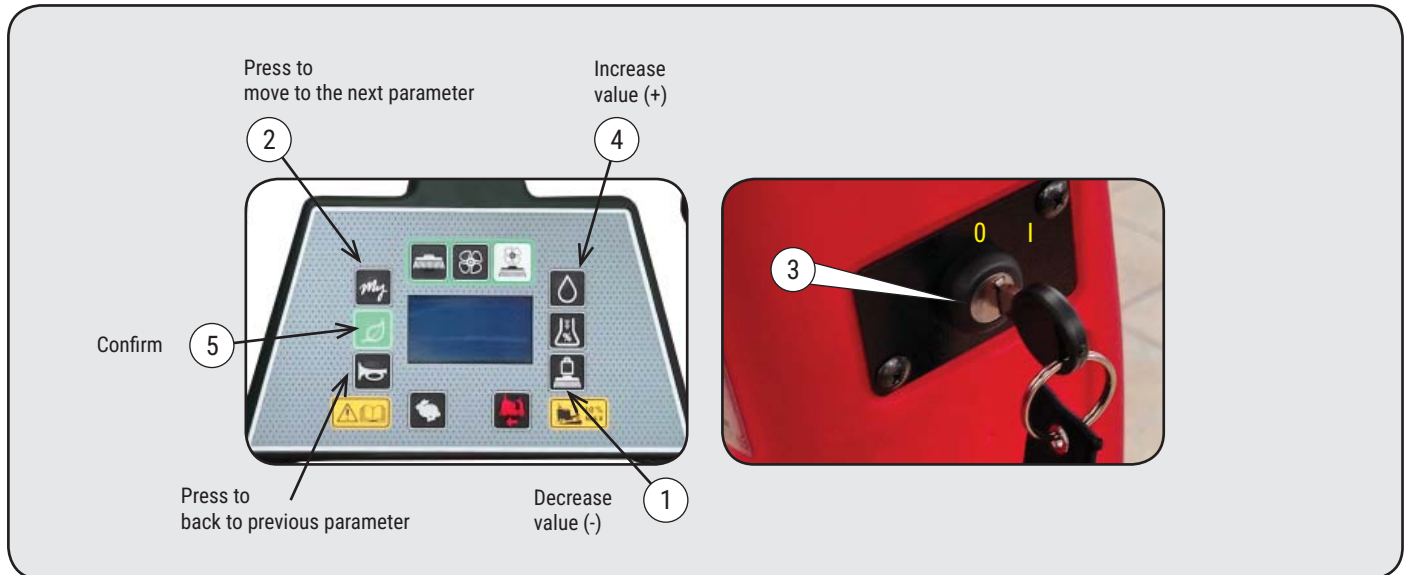

"PASSWORD" selection:

Press button 4, set the password.

Confirm the choice with button 5 to access the parameters and configuration of the machine.

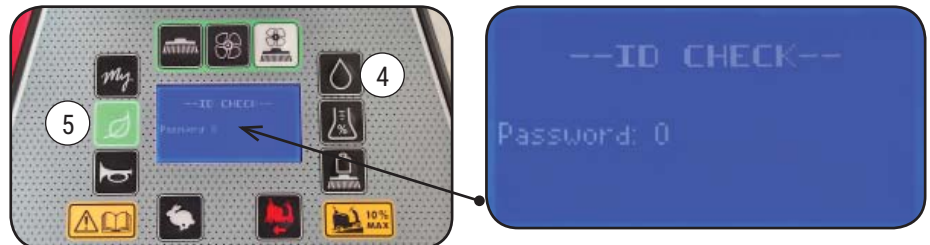

General parameter "MODEL SELECTION":

Press button 4 to select the model.

**NB: set only in case of a different model from the default one.**

- min: LINK 531
- med: LINK 612
- max: LINK 722

Press MY to move to the next parameter.

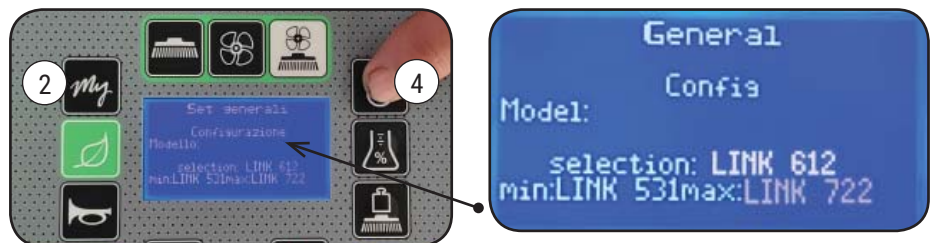

General parameter "HOURMETER":

Press button 4 to reset the machine's partial hourmeter.

- the default parameter is set to the traction of the machine.
- min: NO
- max: ALL

Press MY to move to the next parameter.

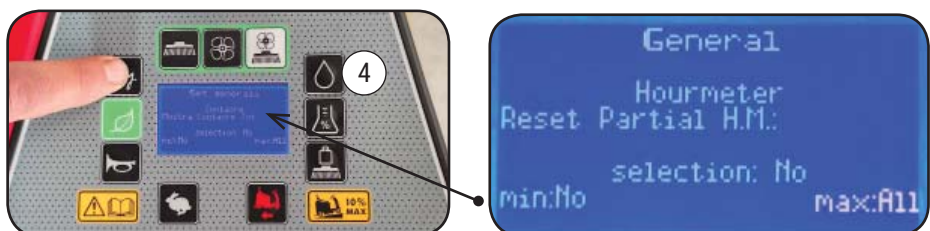

General parameter "BATTERY SELECTION":

Press button 4 to select the type of battery, Lead, Gel, Agm or Lithium "EKT" and display the voltage.

min: Pb60 24V  
max: Lithium 24V

Press MY to move to the next parameter.

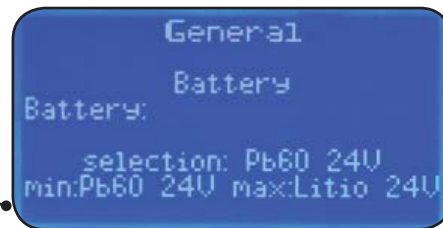

General parameter "LANGUAGE SELECTION":

Press button 4 to select the language type, ITALIAN or ENGLISH.

min: ENG  
max: ITA

Press MY to move to the next parameter.

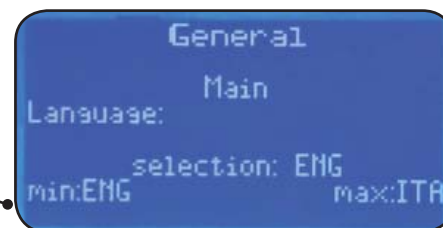

General parameter "DISPLAY CONTRAST SELECTION":

Press button 4 to select the display contrast.

min: 20  
max: 60

Press MY to move to the next parameter.

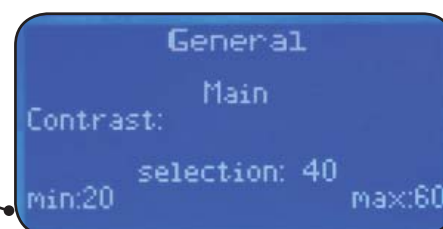

General parameter "LOGO":

Press button 4 to display the LOGO on the display or button 1 not to display it.

min: NO  
max: YES

Press MY to move to the next parameter.

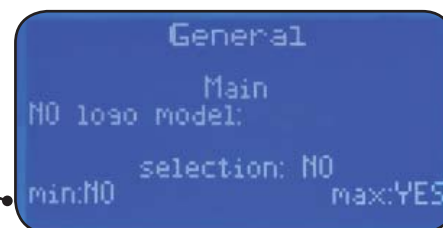

General parameter "BASE VERSION CONFIGURATION":

Press button 4 to select the mode:

0 = standard machine  
1 = machine with water pump (optional)  
2 = machine with water pump and detergent (optional).

min: 0  
max: 2

Press MY to move to the next parameter.

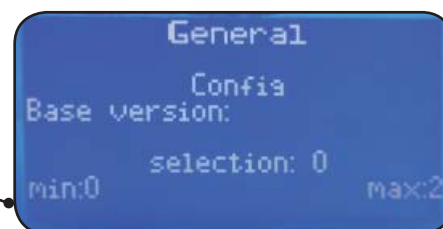
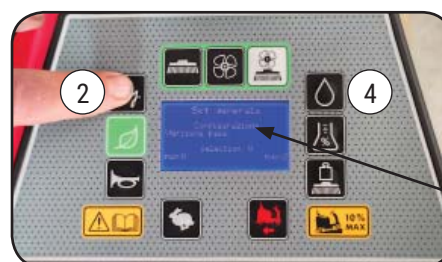

General "SERVICE" parameter:  
 Press button 4 to set the service hours.



min: NO  
 max: 1000

[  Service icon]

Used to activate the request for assistance after a certain established period expressed in hours, the symbol flashes on the display for about 10 seconds. This display will reappear each time the machine is switched on until the hour meter is reset.



**SERVICE**

(THIS DISPLAY REQUESTS ROUTINE MAINTENANCE AT AN AUTHORISED WORKSHOP).

Using the buttons  , for parameter selection, the following modes can be set:

> **NO** (no active mode by default)

> **DEMO** (Selecting this mode the next time the machine is turned on, the display will show the SERVICE icon only once. At the end, when switching off the machine, the parameter automatically returns to **NO**)

> **NO-1000** (Select this mode to set the desired value from **NO to 1000** hours. Once the selection is finished, press the button  to exit the programming or press MY  to move to the next parameter.

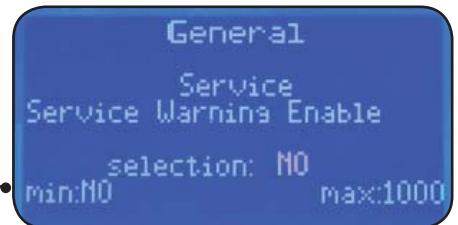

Brush parameter "BRUSH DELAY CONFIGURATION":  
 Press button 4 to adjust the brush motors shutdown delay time.

min: 0.1 seconds  
 max: 10 seconds

Press MY to move to the next parameter.

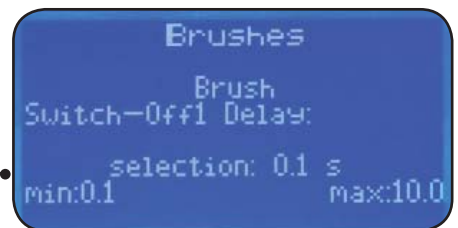

Traction parameter "MAXIMUM MACHINE SPEED CONFIGURATION":

Press button 4 to adjust the maximum speed of the machine.

min: 50  
 max: 100

Press MY to move to the next parameter.



Parameter "INV UPDATE" - FUNCTION BOARD UPDATE:

 **ATTENTION!**  
**TO UPDATE THE FUNCTION BOARD,**  
**CONTACT THE SUPPORT SERVICE.**

Press MY to move to the next parameter.

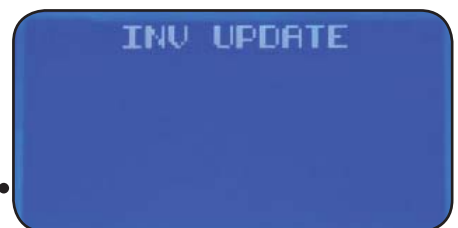

Parameter for "DASH UPDATE " DISPLAY update:

**!** **ATTENTION!**  
**TO UPDATE THE DISPLAY BOARD,**  
**CONTACT THE SUPPORT SERVICE.**

Press MY to move to the next parameter.



"EXIT" parameter:  
Press (5) CONFIRM to exit programming.

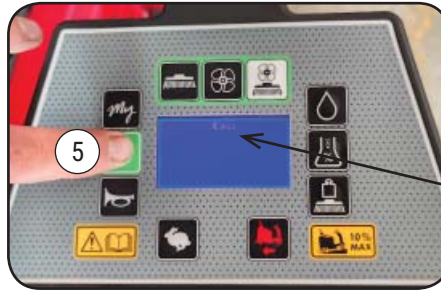

## BATTERY DISCHARGE PERCENTAGE AND ALARM THRESHOLDS

The electronic control unit converts the battery voltage value into a percentage value and provides two alarm thresholds when the battery is discharged at 20% and 10% of its capacity.

Conversion (from voltage to percentage) depends on the type of battery and switching between alarm thresholds follows a delay (settable by parameter).

### Alert Threshold 1:

When the battery discharge level reaches 20%, the "BRUSHES" function is disabled.

### Alert Threshold 2:

When the battery discharge level reaches 10%, the machine switches to transfer mode and the "VACUUM" function is disabled.

Alert Threshold	value	Pb60 (standard)	Gel60 (standard)	Pure Lead	Pb80	Gel80
	%	Volt	Volt	Volt	Volt	Volt
1	20%	21,2	22.2	23.2	20.2	21.7
2	10%	20,8	21.9	23.1	20.0	21.4

### **NB! "EKT" LITHIUM BATTERIES:**

**THE BATTERY COMMUNICATES THE CHARGE LEVEL VIA CAN BUS. THE 10% AND 20% INDICATORS DO NOT CORRESPOND TO THE VOLTAGE.**

## END OF THE WASHING PHASE

After the washing phase, stop the functions using the same buttons described in the various operating modes, go to where the machine is stored and turn it off, remove the ignition key and perform emptying and cleaning.



### **ATTENTION! DANGER OF FROST**

**WITH TEMPERATURES AT 0°C AND BELOW, CHECK AND, IF NECESSARY, COMPLETELY REMOVE THE WATER FROM THE TANKS AND RELATIVE PIPES AT THE END OF EACH JOB OR IF THE MACHINE HAS TO REMAIN STOPPED FOR A CERTAIN PERIOD OF TIME.**

At the end of each wash or when recovery tank 1 is full, drain the dirty water through drain hose 2.

Thoroughly clean tank 1 of filter 3 and waste collection basket 4. Also clean the tank when the machine is not used frequently. Proceed as follows:



**DANGER!**

**DURING CLEANING DO NOT USE CORROSIVE PRODUCTS THAT CAN DAMAGE THE TANK AND YOUR HEALTH. IT IS NECESSARY TO WEAR ADEQUATE CLOTHING, PROTECTIVE GLOVES AND GOGGLES.**

- Open the cover 5 and secure it with the designated support rod 6.
- Remove and clean the filter 3 with a brush and compressed air, the same filter can be washed with water. Once washed, before reassembling it, make sure that it is perfectly dry. Replace the filter if worn.
- Remove and clean the waste collection container 4 by washing it with running water, using a brush remove the accumulated debris.
- To facilitate the internal cleaning of tank 1, lift it and tilt it as shown in the photo.
- Clean the inside with a water jet, allowing debris deposited during washing to exit through the drain hose 2. It is recommended to wait for the tank to dry, then use a compressed air jet (max 1.5 bar) to complete the cleaning.
- Clean gaskets 7 from any debris and check their integrity.

Replace the tank by carry out the above steps in reverse order.



## WATER TANK DRAIN AND WATER FILTER CLEANING

FIG.11

### Solution tank water draining (clean water)

Remove cap 2 to drain the water from solution tank 1. It is recommended to drain the water from the tank when the machine is not used frequently.

### Clean water filter cleaning (solution)

To maintain an efficient filter system, it is necessary to clean solution filter 3 once a month. To clean the filter, do the following:

- Operate on the left side of the machine to unscrew and remove the transparent cover with filter 3 from the seat.
- Remove the filter 4 from the transparent cover 5.
- Clean filter 4 and the transparent cover 5 with a brush and a jet of compressed air, then wash them to remove residual impurities.
- Replace filter 4 in its transparent cover case 5.
- Refit the transparent cover with filter 3, making sure it is completely tightened.

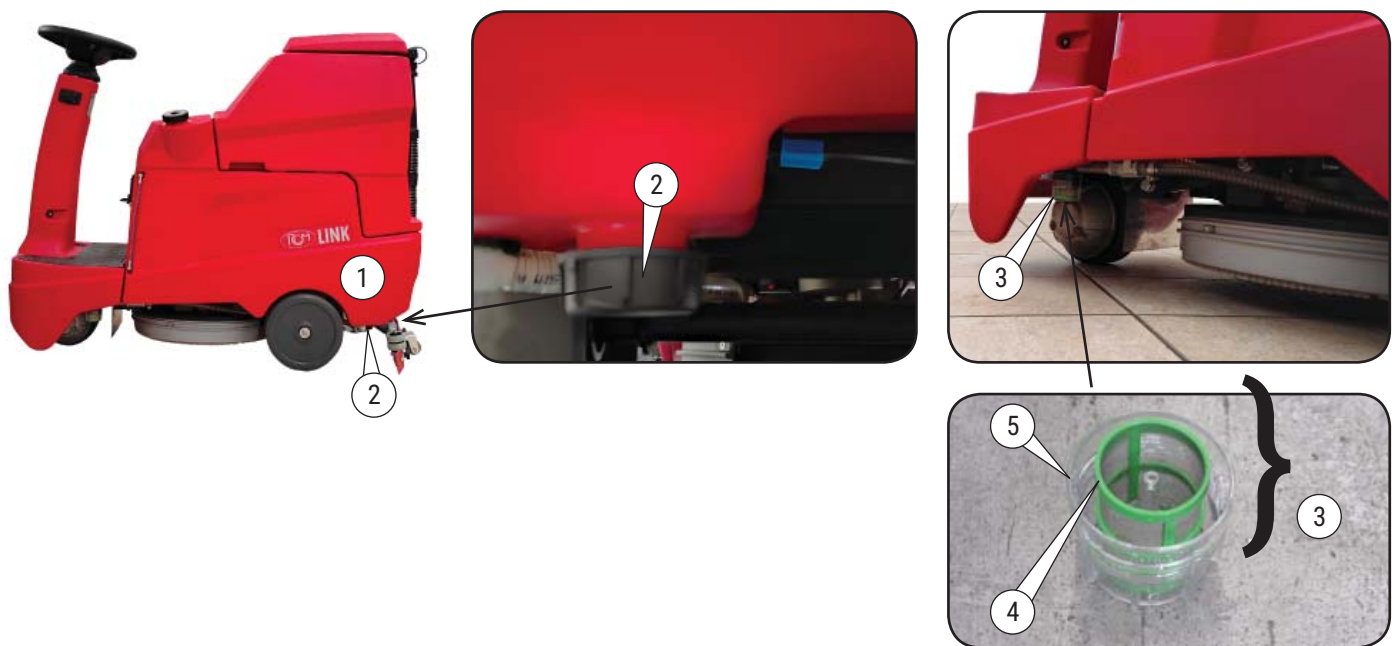



### ATTENTION!

ALL MAINTENANCE OPERATIONS MUST BE CARRIED OUT ONLY BY THE OPERATOR OR AUTHORISED AND QUALIFIED PERSONNEL. BEFORE PROCEEDING AND OPERATING SAFELY, REMOVE THE IGNITION KEY TO PREVENT THE MACHINE OR A MOTOR FROM ACCIDENTALLY SWITCHING ON.

### “Washing” disc brushes (Link 531 - 612 - 722)



### ATTENTION!

BEFORE CARRYING OUT THE MAINTENANCE OF THE “WASHING” DISC BRUSHES, CHECK THAT THERE ARE NO CORDS, WIRES OR OTHER OBJECTS, ETC., WRAPPED AROUND THEM. CHECK THE CONDITION OF TRIANGULAR SUPPORTS 5 AND BRUSHES 4. CHECK THE CLEANLINESS OF THE BRUSHES, IF NECESSARY CLEAN THEM WITH WATER.

Proceed as follows to access the brushes:

- Release the brushes 4 from the triangular supports 5 by performing a snap movement (clockwise or anti-clockwise) and remove them.
- Check the condition of the brushes using a wear marker (M) placed on the brushes themselves, replace them if worn.
- To insert the same brushes or new ones, couple the triangles (T) of the brushes 4 to the triangular supports 5 and perform a snap movement in the opposite direction to the one described above to lock them.

### Splash guard rubber blades (flap)

When damaged, replace the splash guard rubber blades 6 as follows:

- Remove the screws 7 and their plates 8.
- Replace the guard rubber blades 6.

## LINK 531

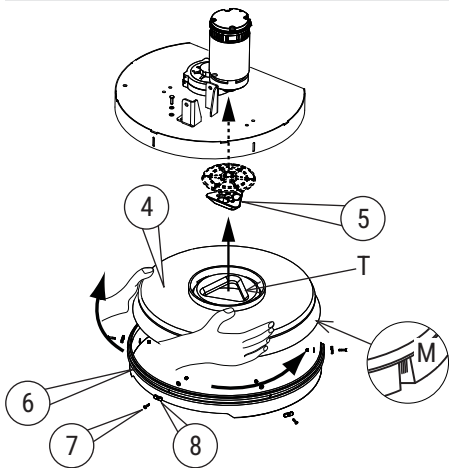

## LINK 612

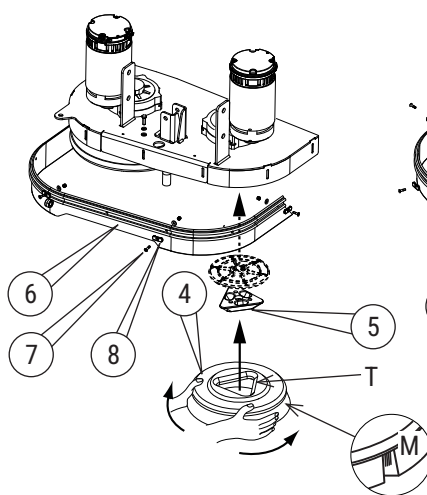

## LINK 722

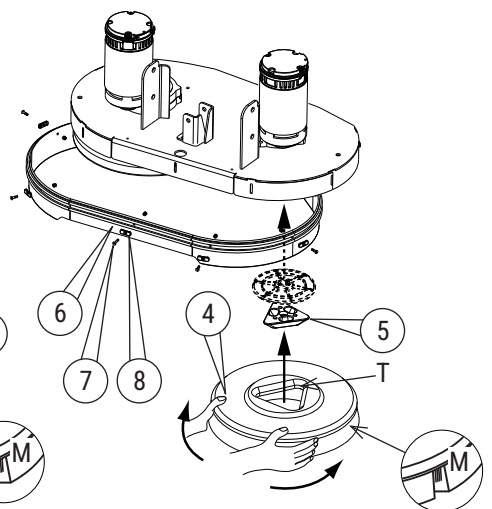

### (M) = Wear marker and bristle type

the colour of the marker on the brush indicates the type of bristle.

When the bristle wears out and reaches the same height as the marker, replace it.

- Red Marker = Brush in PPN 0.6 White
- Blue Marker = Brush in PPN 0.3 White
- Green Marker = Brush in NYLON 0.7 White
- Red Marker = Mischia Brush 5
- Yellow Marker = Brush in Tynex 0.6
- Orange Marker = Brush in Tynex 1.2



## ATTENTION!

PLEASE NOTE THAT FOR PACKAGING REQUIREMENTS THE SQUEEGEE MAY BE SUPPLIED DETACHED FROM THE MACHINE AND MUST BE FITTED ONTO THE SUPPORT PLATE OF THE SCRUBBER-DRYER.

### Installation of the squeegee

Mount the squeegee on the scrubber-dryer drive plate, as follows:

- Insert the pins 1 onto the drive plate 2 and tighten the knobs 3.
- Assemble vacuum pipe 4 on the squeegee.

### Adjustment of the squeegee

For proper operation of the squeegee, the rear blade "P" must operate slightly curved. In this way, liquids are collected from the front side of the rubber. Adjust the inclination of the squeegee using the nut 6, looking for the ideal angle with respect to the floor (as shown in the figure).

Proceed as follows:

- Clockwise rotation to increase tilt.
- Counter-clockwise rotation to decrease tilt.

### Cleaning the squeegee

Remove the squeegee and its rubber blades, and clean them and the inside of the squeegee with a water jet.

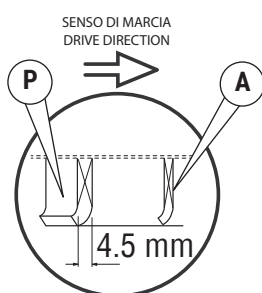

**A = front rubber blade**  
**P = rear rubber blade**

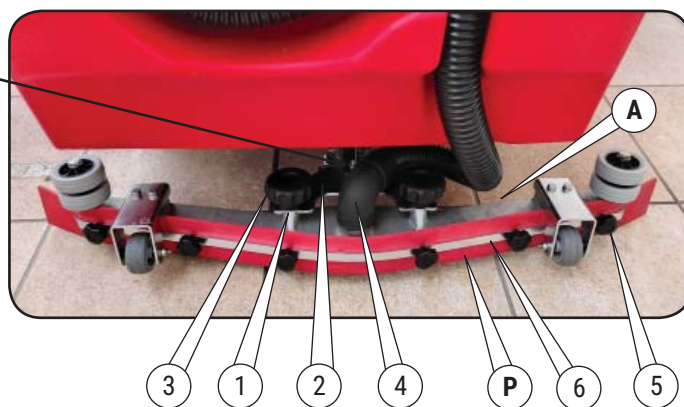

### Changing the drying edge or replacing the squeegee rubber blades

If the front **A** and rear **P** blades of the squeegee do not dry perfectly, then the drying edge must be changed; if the edges are completely worn, replace the blades.

#### Front rubber blade (A)

- Remove the knobs 5 that secure the strip 6 onto the blade.
- Remove the pin screws 7 and the nuts (if present), the strip(s) 8, and the blade (**A**). Turn the blade over and use a fresh edge; replace it if both edges are completely worn.
- Reassemble all components.

#### Rear rubber blade (P)

- If the rear rubber blade (**P**) of the squeegee does not dry perfectly, it will be necessary to change the drying edge; if the edges are completely worn, replace the blade.
- Remove the knobs 5 that secure the strip 6 onto the blade.
- Remove the rubber blade (**P**), turn it over and use a new edge or replace it in case the four edges are completely worn.
- Reassemble all components.

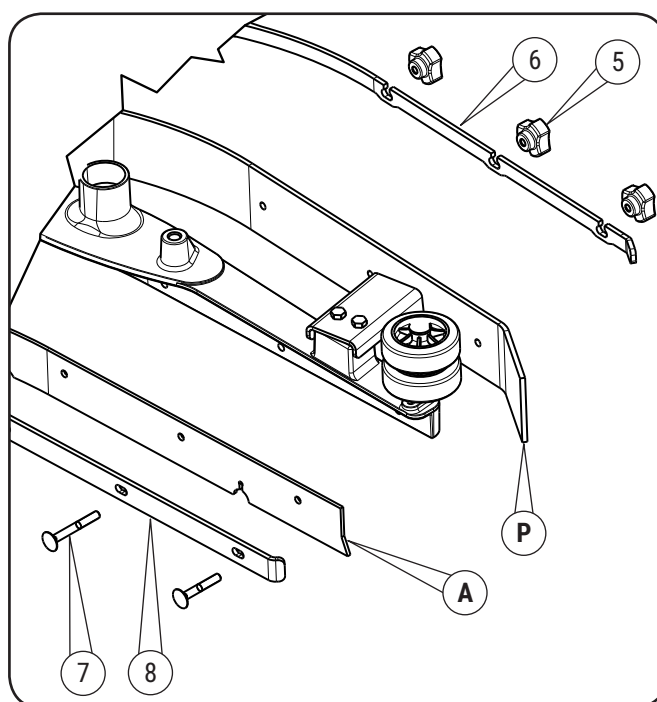

The vacuum motor 1 is used to vacuum up the water collected by the squeegee, by pressing the button 6 {fig. 4}. The same motor must be checked daily and if necessary clean the cartridge filter (if present) 2 and filter 8.

To access and check the vacuum motor, operate as follows:

- Check that the ignition key is not present on the dashboard.
- Lift the recovery tank to access the battery compartment and the intake motor.
- Unscrew the screw 3, remove the cover 4 of the suction motor.
- Remove the sound-absorbing protection 5 and sealing ring (if present) 6.
- Disconnect the connection connector of the vacuum motor and of the battery.
- Loosen the nuts 7 and turn the motor anti-clockwise, releasing it from its seat and slide it off (as indicated by the arrow in the photo).

To reassemble, proceed in the reverse order.



### ATTENTION!

**CHECK THE CARBON BRUSHES OF THE VACUUM MOTOR FOR WEAR EVERY SIX MONTHS, REPLACING THEM IF REQUIRED.**

To check the brushes, proceed as follows:

- Remove the plastic cover 9.
- Loosen the screws.
- Take off the plastic supports of the carbon brushes.
- Check them and replace them if worn.

To reassemble, proceed in the reverse order.

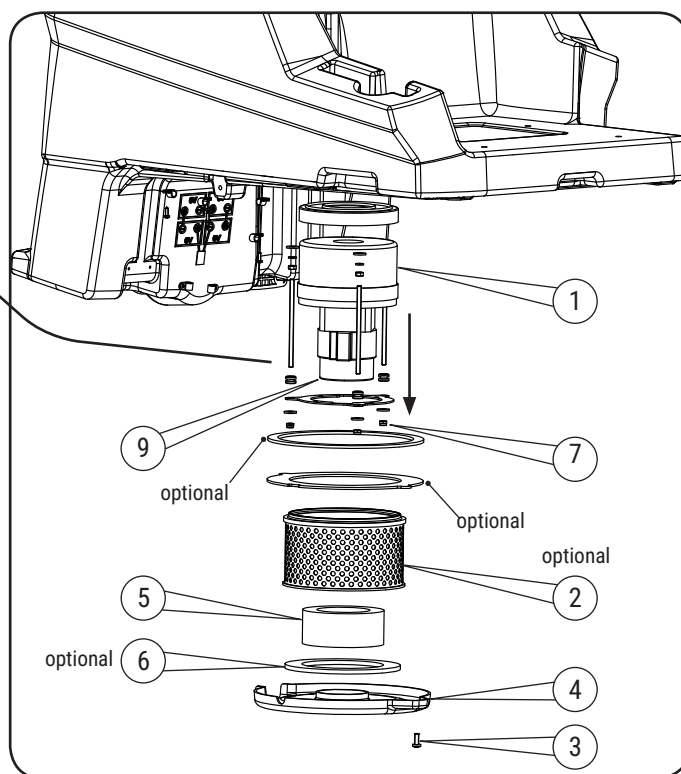
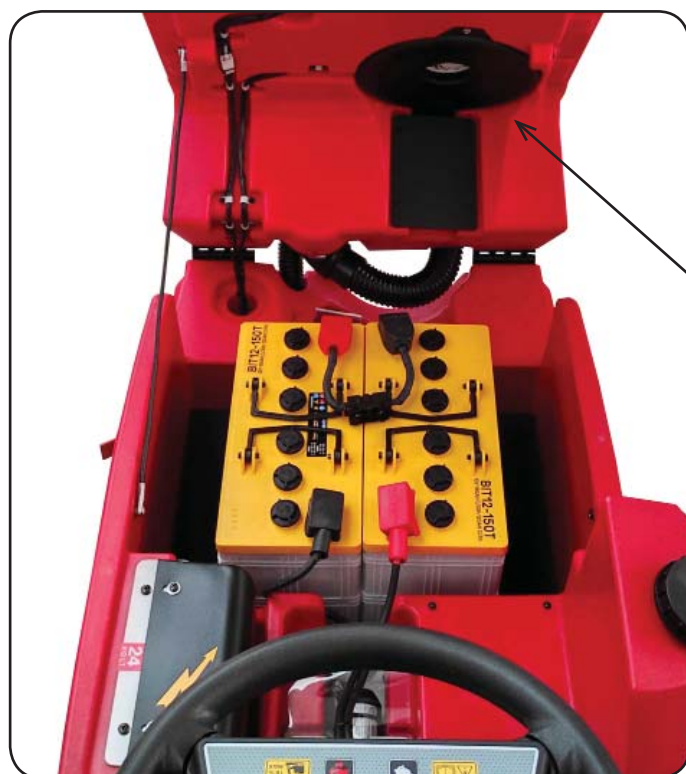

The scrubber-dryer is driven by an electrical system consisting of an electric motor-wheel 1 with electric brake 2, by an electronic control unit 3 that controls the travel system.

The machine is designed for forward travel by pressing the accelerator pedal 4.  
The dashboard has a reverse gear button 5 and a button 6 for adjusting the operating or transfer speed.

## Manual handling of the machine when it is not possible to use the drive (traction)

### ! ATTENTION!

**WHEN IT IS NOT POSSIBLE TO USE THE TRACTION (IN CASE OF MISSING BATTERIES, DISCHARGED BATTERIES, NOT CONNECTED OR FAULTY, ETC...), AND YOU WANT TO MOVE THE MACHINE MANUALLY BY PUSH OR TOW, YOU MUST DEACTIVATE THE ELECTROMAGNETIC BRAKE BY PROCEEDING AS DESCRIBED IN THE SECTION "PUSHING AND TOWING THE MACHINE {FIG.17} AND "BRAKING".**

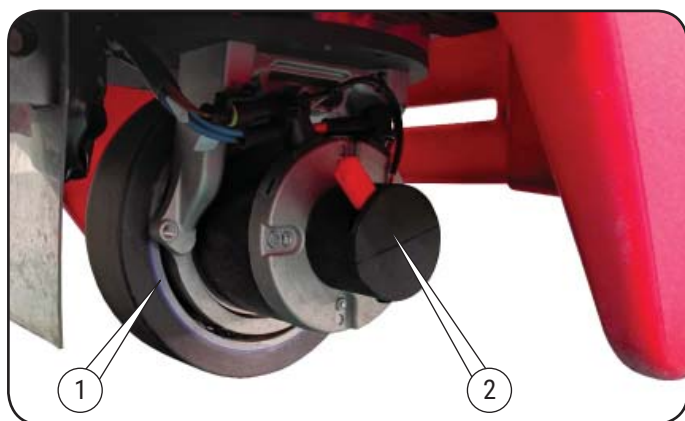

# STEERING

# FIG.16

The steering is of a mechanical type, the steering wheel 1 transmits the motion to the column 2 and sprocket 3 and to the crown wheel 4 on the front wheel 5. To adjust any play in the steering wheel, loosen the screws 6 and move the plate 7 forwards or backwards.

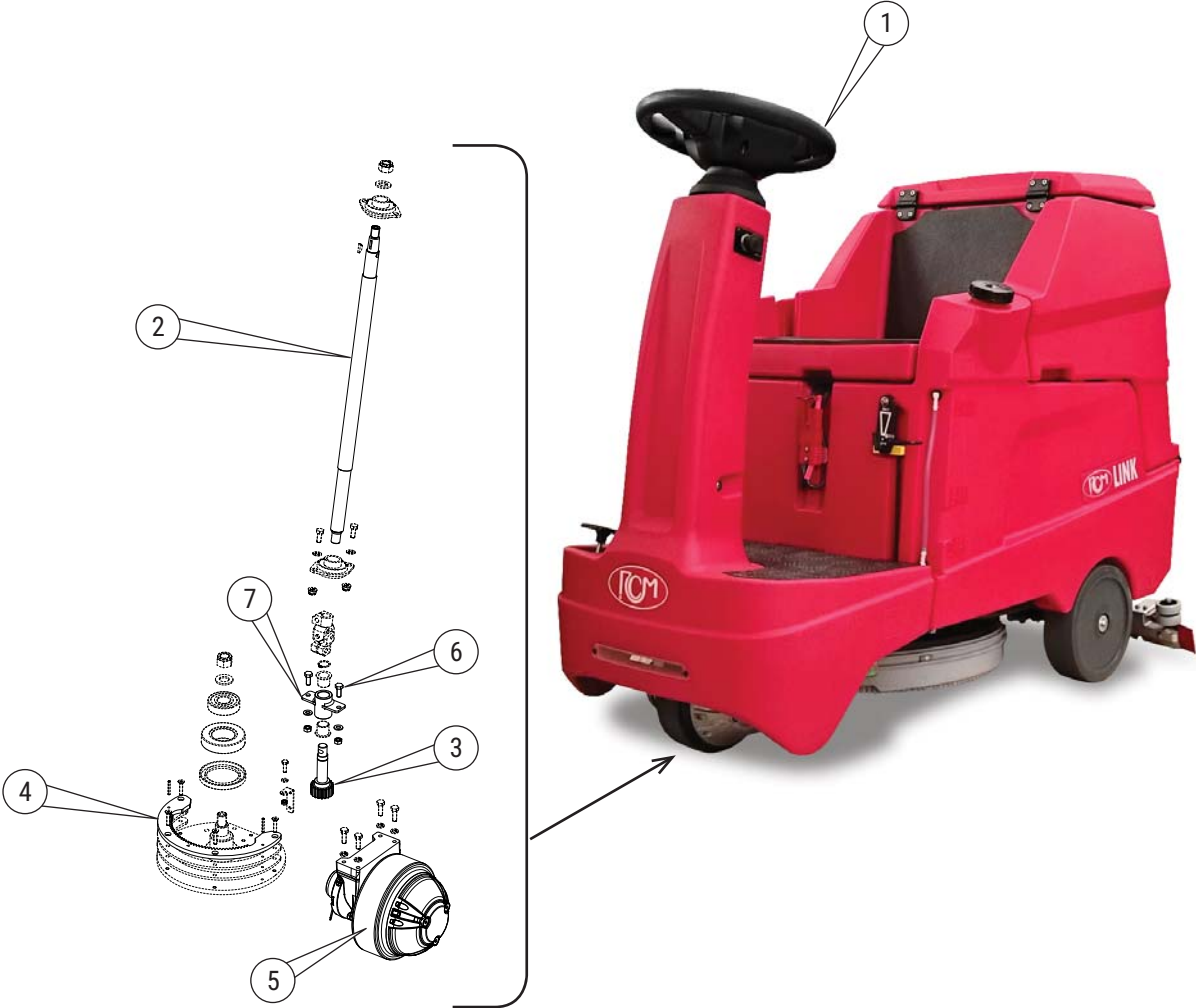

To move the machine manually by pushing or towing, deactivate the electromagnetic brake 2 placed on the front electro-wheel 3, proceeding as follows:

- Rotate the lever 1 in a "CLOCKWISE" direction as shown in the photo.



### ATTENTION!

**TOWING THE SCRUBBER DRYER WITH OTHER VEHICLES IS NOT ALLOWED.**

**WHEN THE MACHINE IS SWITCHED OFF, PUSHING OR MANUAL TOWING IS ALLOWED, AT A SPEED NOT EXCEEDING 2 KM/H.**

- Once this operation is finished, turn the lever 1 "counter-clockwise" to reactivate the electromagnetic brake and return the machine to safe conditions.



### ATTENTION!

**AFTER MANUALLY MOVING THE MACHINE AND REACTIVATING THE ELECTROMAGNETIC BRAKE 2, CHECK ITS BRAKING CONDITION BY PUSHING THE MACHINE AND VERIFYING THAT THE ELECTROMAGNETIC BRAKE HAS BEEN PROPERLY RE-ENGAGED.**



### ATTENTION!

**NEVER SWITCH ON THE MACHINE WITH THE LEVER 1 IN THE ELECTROMAGNETIC BRAKE UNLOCKED POSITION. RELEASE THE ELECTROMAGNETIC BRAKE ONLY FOR THE TIME STRICTLY NECESSARY FOR THE MANUAL PUSHING OR TOWING MOVEMENT OF THE MACHINE.**

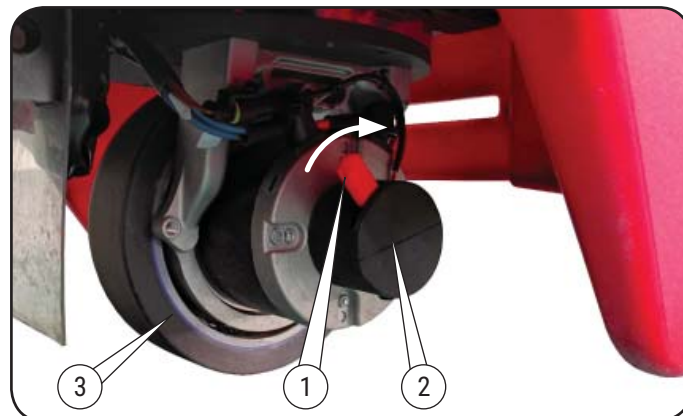

## BRAKING

Braking is assisted by the electromagnetic brake 2. The electromagnetic brake is integrated into the traction system of the front electric wheel 3, the brake keeps the machine braked when it is switched off or when it is switched on but stationary. The electromagnetic brake is equipped with a lever 1 to unlock and manually move the machine when it is stopped. (for example: in the absence of the battery). See: "PUSHING AND TOWING THE MACHINE".



### ATTENTION!

**IF THE ELECTROMAGNETIC BRAKE IS RELEASED, THE MACHINE WILL NOT BRAKE.**

**NEVER USE THE MACHINE WITH THE BRAKE RELEASED.**



**ATTENTION!**

**BEFORE INSTALLING THE BATTERIES, CHECK THAT THEY ARE CLEAN AND IN GOOD CONDITION. INSTALL THE BATTERIES IN THE COMPARTMENT 6 INTEGRATED IN THE SOLUTION TANK 7.**

**Batteries**

On the machine it is possible to install 4 x 6V "1" batteries (connect the batteries as per the "battery connection diagram") or 2 x 12V Lead Acid batteries or 25.6V "EKT" lithium batteries (see section "TECHNICAL FEATURES").

For the installation of 6V or 12V batteries it is necessary to use the crossbars 8 to lock the batteries in the compartment 6 (see fig.18 2/2 - battery installation).

To access the battery compartment 6, proceed as follows:

- Make sure that recovery tank 2 is empty and tilt it using the maximum extension of cable 3, as indicated in the photo.



**ATTENTION!**

**IF LEAD-ACID BATTERIES ARE INSTALLED ON THE MACHINE AND YOU WISH TO REPLACE THEM WITH GEL BATTERIES OR A EKT LITHIUM BATTERY, OR VICE VERSA, THE BATTERY TYPE PARAMETER MUST BE MODIFIED AS DESCRIBED IN "FIG.9". THIS OPERATION MUST ONLY BE CARRIED OUT BY "RCM" OR A "QUALIFIED" DEALER.**



**ATTENTION!**

**IF THE ON-BOARD CHARGER IS PRESENT ON THE MACHINE FIG. 20 AND IF THE BATTERIES TO BE INSTALLED ARE GEL, AGM OR ACID LEAD OR VICE VERSA, CARRY OUT THE SPECIFIC SETTINGS FOR THE TYPE OF BATTERY USING THE DIP-SWITCHES PLACED ON THE CHARGER ITSELF (SEE FIG.20).**

**IF THE BATTERIES TO BE INSTALLED ARE "EKT" LITHIUM, USE AN ON-BOARD CHARGER SUITABLE FOR "EKT" LITHIUM BATTERIES (FIG.21).**

**Electronic control unit and dashboard (display)**

The scrubber is equipped with an 4-power electronic control unit for feed control, and a dashboard panel 5 with multi-function display for the washing programs and calibrations. To access the control unit, tilt the recovery tank as described for installing the batteries. This type of equipment also includes the diagnostic function of any issues that may arise. The diagnostics are indicated by the dashboard board 5 with display (see CONTROL UNIT ALARMS section).

The same electronic control unit manages the battery discharge capacity as described in the section "BATTERY DISCHARGE PERCENTAGE AND ALERT THRESHOLDS".

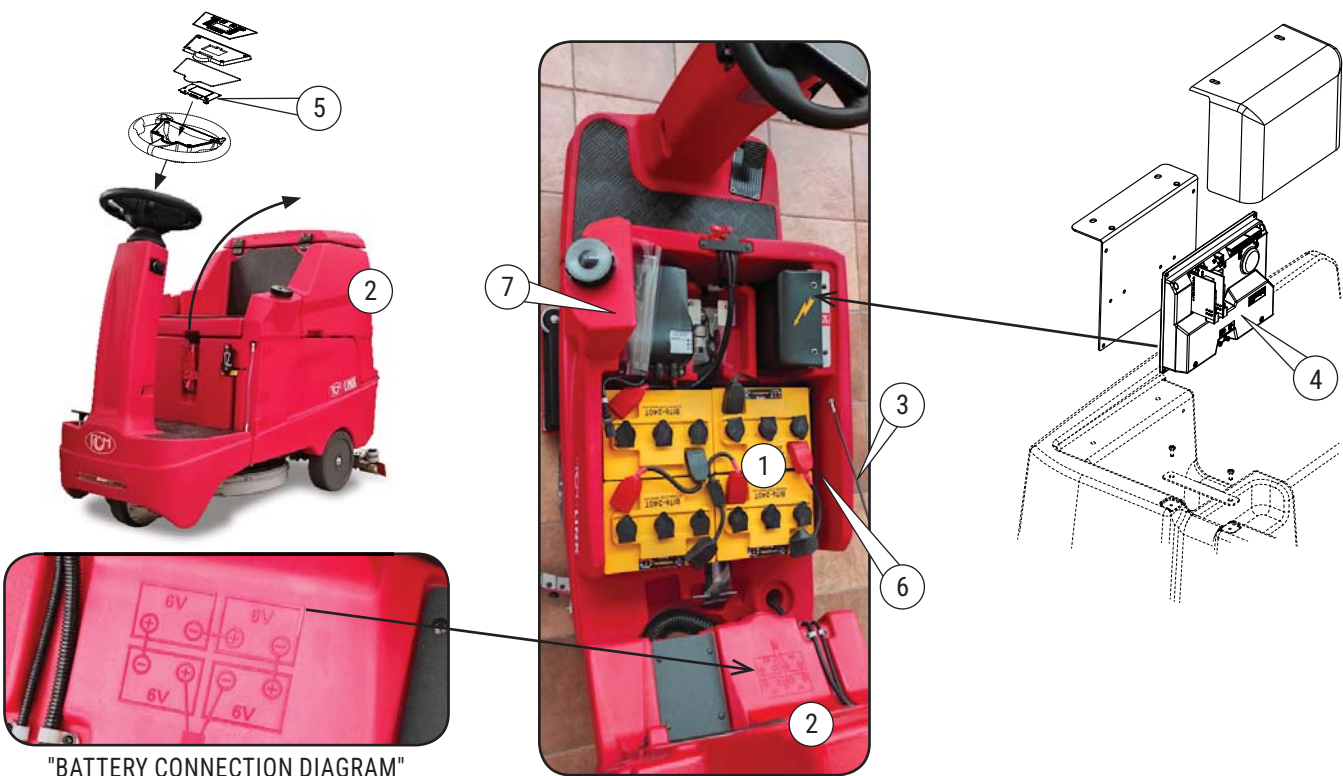

"BATTERY CONNECTION DIAGRAM"

## 6V Batteries Installation

For the installation of 4 x 6V batteries inside the battery compartment 6 obtained in the solution tank 7, place a single crossbar 8 as shown in the figure.

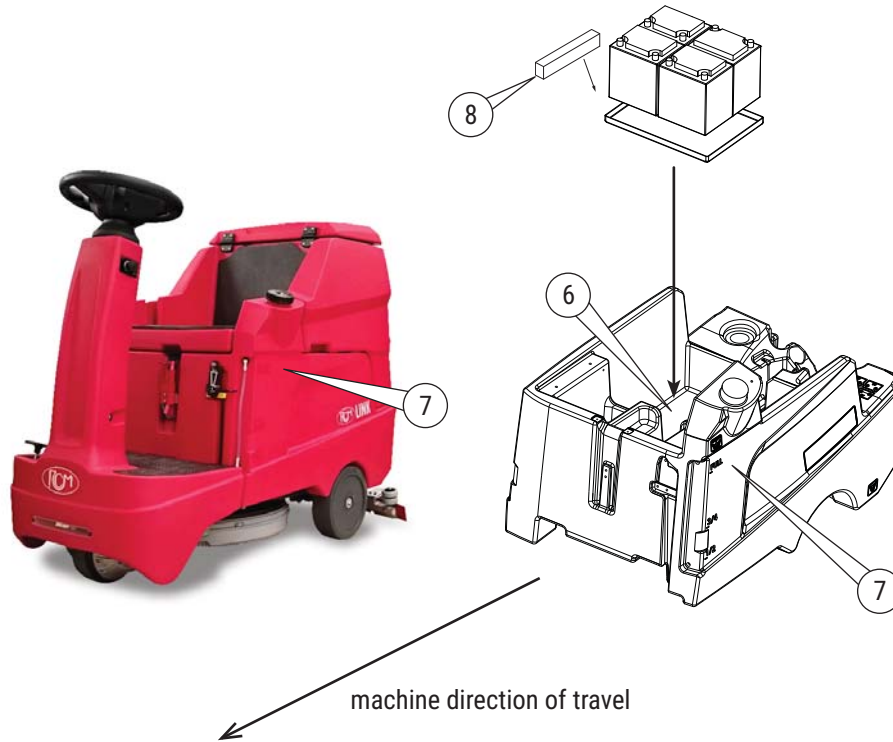

## 12V Batteries Installation

For the installation of 2 x 12V batteries inside the battery compartment 6 obtained in the solution tank 7, position 7 x crossbars 8 as shown in the figure.

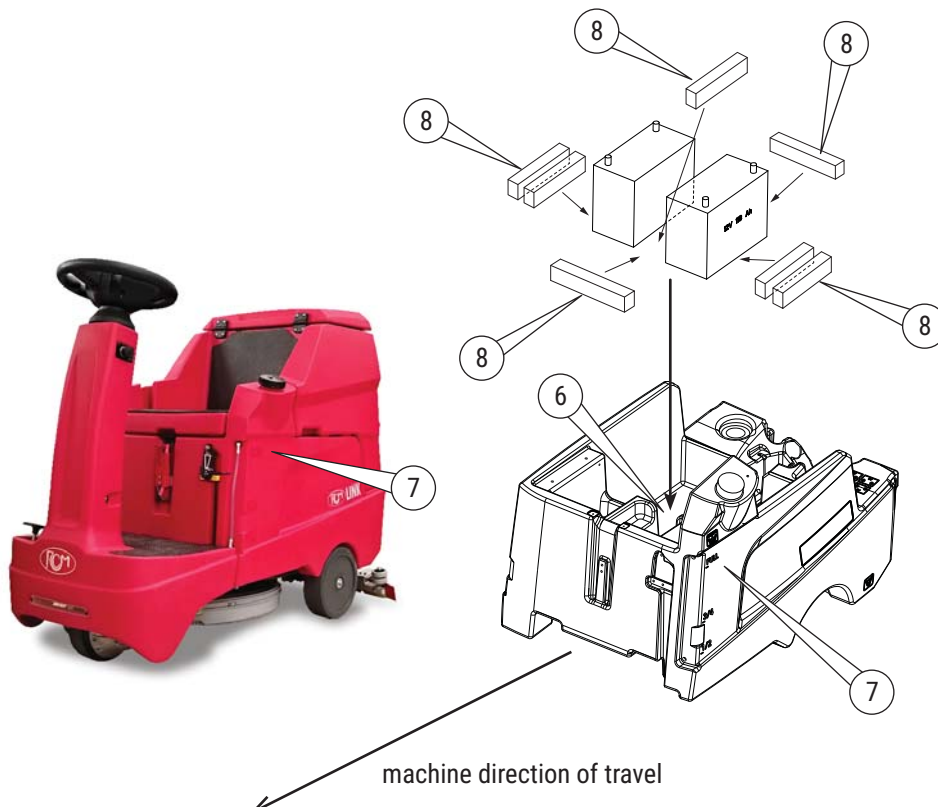

## STANDARDS FOR RECHARGING BATTERIES WITH ON-BOARD OR OFF-BOARD CHARGERS



### **DANGER! RISK OF DAMAGE**

**NEVER ATTEMPT TO CHARGE THE BATTERY WITH A CHARGER OTHER THAN THE ONE SUPPLIED WITH THE SCRUBBER-DRYER, OR WITH SPECIFICATIONS OTHER THAN THOSE INDICATED. THIS COULD CAUSE IRREPARABLE DAMAGE TO THE BATTERY, CHARGER AND/OR SCRUBBER-DRYER, AS WELL AS CREATE HAZARDOUS SITUATIONS (FIRE, EXPLOSION).**



### **ATTENTION!**

**AVOID CHARGING THE BATTERY IN ENVIRONMENTS WITH EXTREME TEMPERATURES (TOO COLD OR TOO HOT). REFER TO THE TECHNICAL FEATURES OF THE BATTERY. MAKE SURE THAT THE AREA WHERE CHARGING TAKES PLACE IS WELL VENTILATED.**

**DO NOT SMOKE AND KEEP OPEN FLAMES AWAY.**

### **PERIODIC CHECKS:**

**REGULARLY INSPECT THE CHARGER POWER CORD AND CONNECTORS FOR ANY SIGNS OF WEAR OR DAMAGE.**

# "SPE CBHD3" ON-BOARD CHARGER FOR LEAD-ACID, GEL, AND AGM BATTERIES

FIG.19A

## "SPE CBHD3 24V 25A" on-board charger (Optional)

The on-board charger is designed for recharging lead acid, gel and AGM batteries. (see Dipswitch settings table (Fig.20A).



**ATTENTION!**

**WHEN THE BATTERY CHARGER IS CONNECTED TO THE MAINS, ALL MACHINE FUNCTIONS ARE AUTOMATICALLY EXCLUDED.**



**ATTENTION!**

**DO NOT USE WITH AGM (ARMOURED) OR LITHIUM BATTERIES.**

The charger 1 "if present" is located in the battery compartment. To access it, proceed as described in the section "ELECTRICAL SYSTEM - Batteries - Fig.18 1/2".

## Charging the batteries on-board battery charger (optional)



**ATTENTION!**

**READ THE INSTRUCTION MANUAL SUPPLIED WITH THE "CBHD3 24V 25A" BATTERY CHARGER.**

The electrical system has a voltage of 24V powered by a group of four 6V batteries (24V-MAX. 180Ah or 210Ah).

The scrubber must never be used until the batteries are completely flat. The battery charge status is indicated by the symbol on the display.

When the battery reaches 20% charge, the brush function is inhibited. Traction and suction remain active, allowing the drying phase to be completed and the machine to be transferred to the charging point.

When 10% of the battery charge is reached, the suction function is also inhibited, traction remains active, allowing the machine to be transferred to the charging point.

Proceed as follows to recharge the batteries:

- Connect socket 3 on plug 4 of battery charger 1.
- Connect plug 5 to the 220V power socket 6.

At this point the charging phase begins, the red LED 7 on the battery charger will begin flashing. During the recharge phase, the LEDs change from:

Red LED 7 = Battery Low

Yellow LED 8 = Battery semi-charged

Green LED 9 = Battery charged

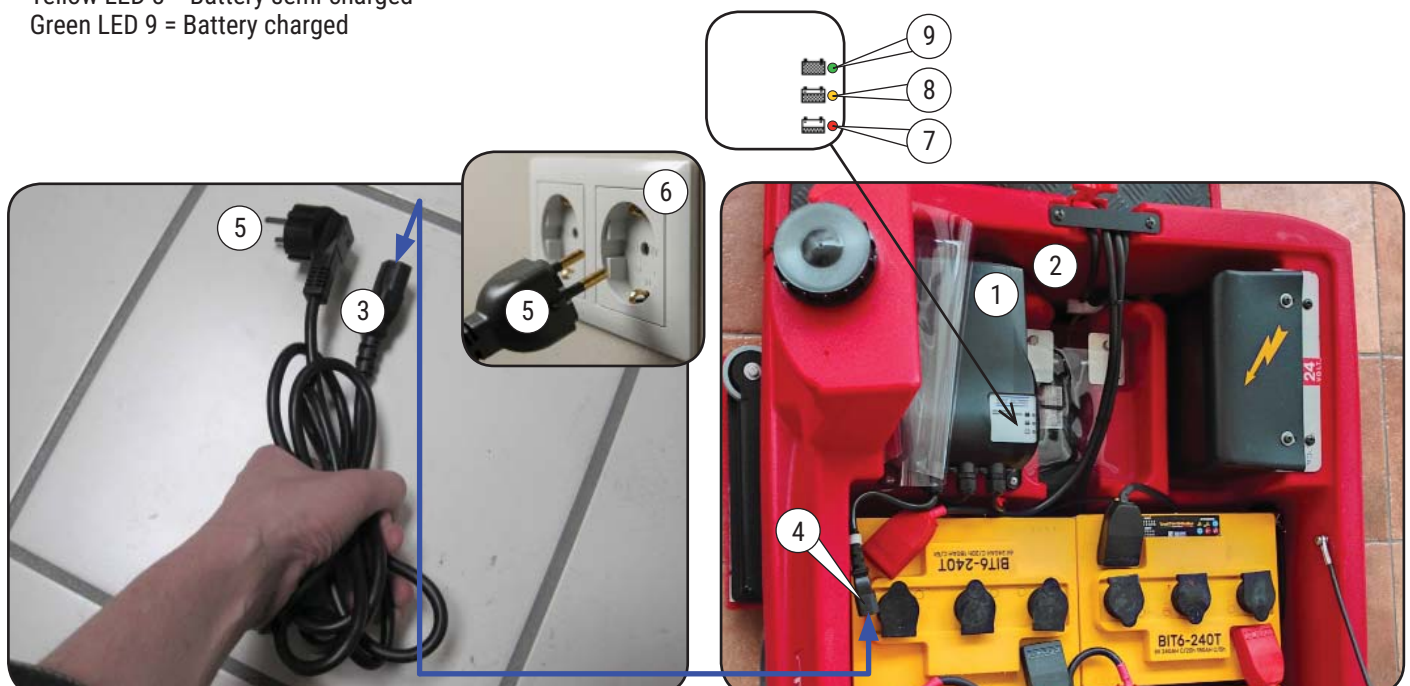

# "NORDELETRONICA NE286" ON-BOARD CHARGER FOR LEAD-ACID, GEL, AND AGM BATTERIES

FIG.19B

## "NORDELETRONICA NE286 24V 13A" on-board charger (Optional)

The on-board charger is designed for recharging lead acid, gel and AGM batteries. (see Dipswitch settings table (Fig.20B)).



### ATTENTION!

**WHEN THE BATTERY CHARGER IS CONNECTED TO THE MAINS, ALL MACHINE FUNCTIONS ARE AUTOMATICALLY EXCLUDED.**



### ATTENTION!

**DO NOT USE WITH AGM (ARMOURED) OR LITHIUM BATTERIES.**

The charger 1 "if present" is located in the battery compartment. To access it, proceed as described in the section "ELECTRICAL SYSTEM - Batteries - Fig.18 1/2".

## Charging the batteries on-board battery charger (optional)



### ATTENTION!

**READ THE INSTRUCTION MANUAL SUPPLIED WITH THE "NE286 24V 13A" BATTERY CHARGER.**

The electrical system has a voltage of 24V powered by a group of four 6V batteries (24V-MAX. 180Ah or 210Ah).

The scrubber must never be used until the batteries are completely flat. The battery charge status is indicated by the symbol on the display.

When the battery reaches 20% charge, the brush function is inhibited. Traction and suction remain active, allowing the drying phase to be completed and the machine to be transferred to the charging point.

When 10% of the battery charge is reached, the suction function is also inhibited, traction remains active, allowing the machine to be transferred to the charging point.

Proceed as follows to recharge the batteries:

- Connect the socket 3 to the socket 4 of the battery charger and the plug 5 to the electrical socket 6. When the charger is switched on, the three LEDs 2\* light up, then the green LED flashes to indicate the charge curve of the type of battery, Lead, Gel or AGM. See the charge curve setting table (FIG.20B).

The charger will start charging the batteries, indicated by the red LED on the charger.

The three LEDs 2\* indicate the charging phase:

\*Red LED = 1st stage, initial charging.

\*Yellow LED = 2nd stage, constant voltage charging.

\*Green LED = 3rd stage, end-of-charge and maintenance.

Green LED    Yellow LED    Red LED

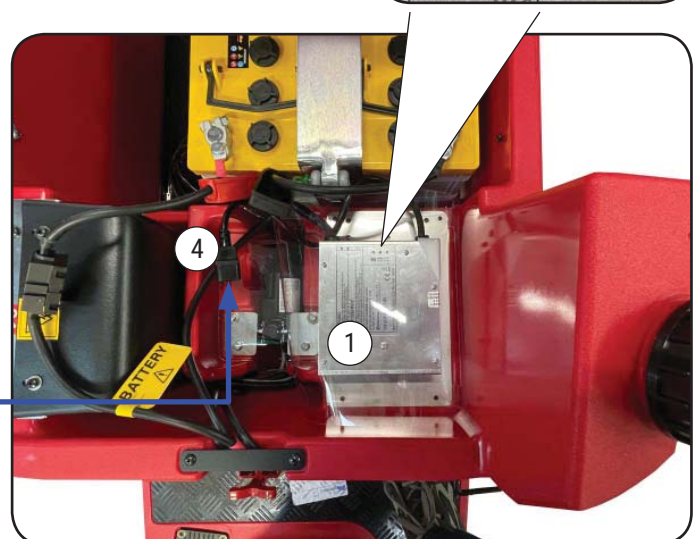
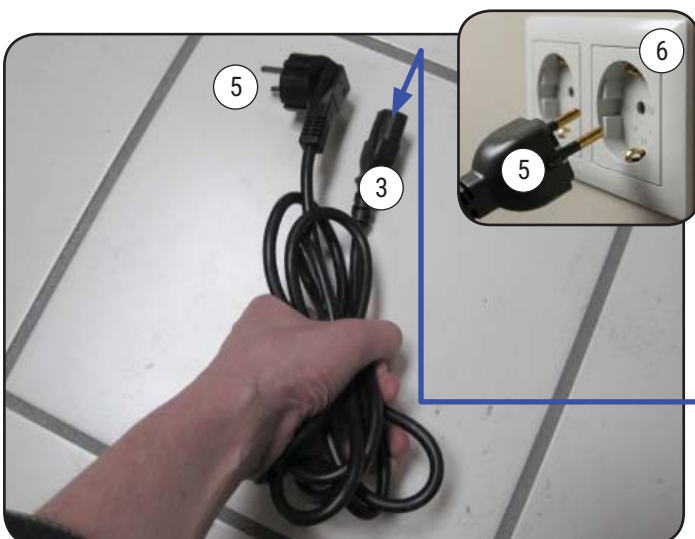
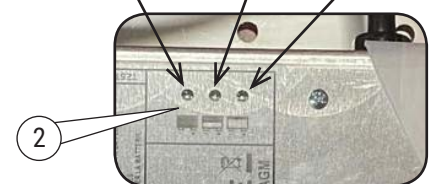

# “SPE CBHD3” ON-BOARD CHARGER DIPSWITCH CONFIGURATION (LEAD-ACID, GEL, AND AGM BATTERIES)

**FIG.20A**



**ATTENTION!**

**TO AVOID DAMAGING THE CONNECTED BATTERIES, SELECT THE CHARGE CURVE CORRESPONDING TO THE BATTERY TYPE, FOLLOWING THE INSTRUCTIONS SHOWN IN THE TABLE BELOW.**



**ATTENTION!**

**IF LEAD-ACID, GEL OR AGM BATTERIES ARE INSTALLED ON THE SCRUBBER-DRYER, PERFORM THE SPECIFIC SETTINGS USING THE DIPSWITCHES PLACED ON THE BATTERY CHARGER FOLLOWING THE SPECIFIC CURVES AS DESCRIBED IN THE TABLE BELOW.**

**"DIPSWITCH" configuration on the SPE CBHD3 on-board charger for recharging lead acid, gel or AGM batteries (Optional)**

The SPE CBHD3 on-board charger is designed for recharging lead acid, gel or AGM batteries.

The charger configuration has four curves. Each curve is dedicated to a single type of battery and is identified by a flashing LED.

The settings according to the type of battery must be made using the Dipswitches 1 (see photo) with reference to the "Dipswitch configuration table for CBHD3 24V - 25A" battery charger.

To access the Dipswitches, lift the plate 2.

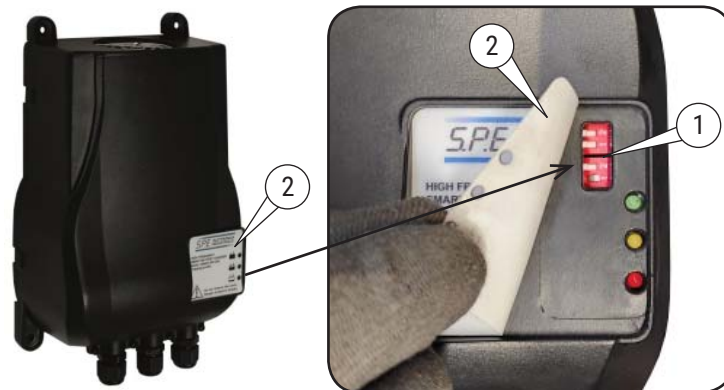

**DIPSWITCH configuration table for SPE CBHD3 24V-25A charger**

SW1		Charge curve
DIP 1	DIP 2	
ON	ON	3 (IUIU0 curve for EV DISC batteries)
-> ON	OFF	0 (IU1a curve for lead-acid batteries)
OFF	ON	2 (IUU0 curve for AGM Fullriver batteries)
-> OFF	OFF	1 (IU1a curve for GEL batteries)

SW2	
DIP1	DIP2
Current 15A	Voltage 12V
Current 25A	Voltage 24V

# "NORDELETRONICA NE286" ON-BOARD CHARGER DIPSWITCH CONFIGURATION (LEAD-ACID, GEL, AND AGM BATTERIES)

**FIG.20B**

## "DIPSWITCH" configuration on the NORDELETRONICA NE286 on-board charger for recharging lead acid, gel or AGM batteries (Optional)

The NORDELETRONICA NE286 on-board charger is designed for recharging lead acid, gel or AGM batteries.

The charger configuration has eight charging curves and is identified by the flashing of the green LED.

The settings according to the type of battery must be carried out using the Dipswitch 1 switches (see photo) referring to the "Dipswitch configuration table for NORDELETRONICA NE286 24V 13A charger".

To access the Dipswitches 1, remove the cap 2 on the charger.

**Charge curve table for "NORDELETRONICA" charger**

S1	S2	S4	Reference DIPSWITCH	Charge curve	Yellow LED status when switched on	Number of flashes of green LED when switched on
OFF	OFF	OFF	1	IUI0-Pb for lead acid batteries	OFF	1
ON	ON	OFF	2	IUIa-Pb for lead acid batteries	OFF	2
OFF	ON	OFF	3	IUA for Zenith AGM batteries	OFF	3
ON	OFF	OFF	4	IUI0 for AGM EV-Discover batteries	OFF	4
OFF	OFF	ON	5	IUoU for AGM GEL BATTERIES	ON	1
ON	ON	ON	6	IUoU for Trojan GEL BATTERIES	ON	2
OFF	ON	ON	7	IUI0 for Sonnenschein GEL BATTERIES	ON	3
ON	OFF	ON	8	IUIa for Sonnenschein GEL BATTERIES	ON	4

S3	Function
-	none

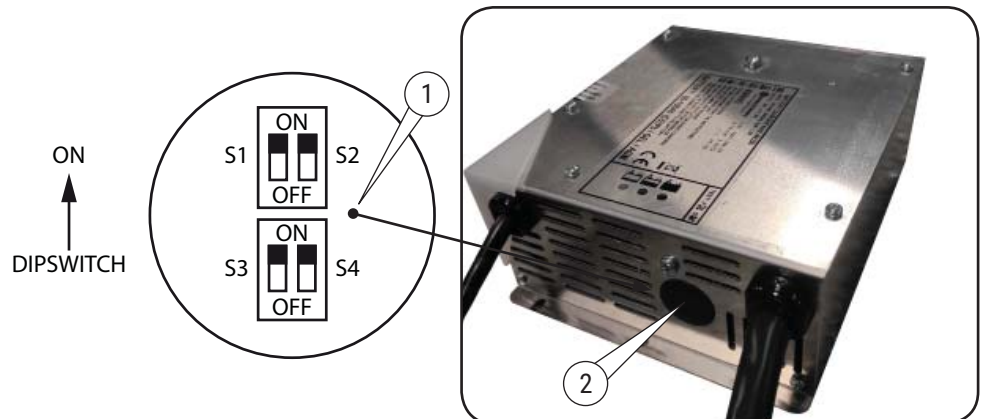

# ON-BOARD CHARGER (LITHIUM "EKT" BATTERIES)

FIG.21



## **DANGER! RISK OF DAMAGE**

**NEVER ATTEMPT TO CHARGE THE BATTERY WITH A CHARGER OTHER THAN THE ONE SUPPLIED ON THE SCRUBBER-DRYER, OR WITH SPECIFICATIONS DIFFERENT FROM THOSE INDICATED. THIS COULD CAUSE IRREPARABLE DAMAGE TO THE BATTERY, CHARGER AND/OR SCRUBBER-DRYER, AS WELL AS CREATE HAZARDOUS SITUATIONS (FIRE, EXPLOSION).**



## **ATTENTION!**

**AVOID CHARGING THE BATTERY IN ENVIRONMENTS WITH EXTREME TEMPERATURES (TOO COLD OR TOO HOT). REFER TO THE TECHNICAL FEATURES OF THE BATTERY. MAKE SURE THAT THE AREA WHERE CHARGING TAKES PLACE IS WELL VENTILATED.**

## **PERIODIC CHECKS:**

**REGULARLY INSPECT THE CHARGER POWER CORD AND CONNECTORS FOR ANY SIGNS OF WEAR OR DAMAGE.**

## **On-board charger "24V-30A model EKT CHBOB24V30A" (Optional)**

The on-board charger "1" is designed for recharging the 25.6V - 90Ah lithium "2" model EKTMS2490 or 3 x 25.6V - 150Ah model EKTMS24150 batteries.



## **ATTENTION!**

**WHEN THE BATTERY CHARGER IS CONNECTED TO THE MAINS, ALL MACHINE FUNCTIONS ARE AUTOMATICALLY EXCLUDED.**



## **ATTENTION!**

**DO NOT USE WITH AGM, GEL, OR LEAD-ACID BATTERIES**

The charger 1 "if present" is located in the battery compartment. To access it, proceed as described in the section "ELECTRICAL SYSTEM - Batteries - Fig.18 1/2".

## **Charging the batteries on-board battery charger (optional)**



## **ATTENTION!**

**READ THE INSTRUCTION BOOKLET SUPPLIED WITH THE "EKT CHBOB24V30A" MODEL CHARGER .**

The electrical system has a voltage of 24V powered by a lithium battery "ekt 25.6V - 90Ah or 25.6V - 150Ah".

The scrubber must never be used until the battery is completely flat. The battery charge status is indicated by the symbol on the display.

When the battery reaches 20% charge, the brush function is inhibited. Traction and suction remain active, allowing the drying phase to be completed and the machine to be transferred to the charging point.

When 10% of the battery charge is reached, the suction function is also inhibited, traction remains active, allowing the machine to be transferred to the charging point.

To recharge the "EKT" lithium battery, proceed as follows:

Connect the charger 1 to the power outlet. The charging procedure will be initiated and managed by the battery until full charge is reached.

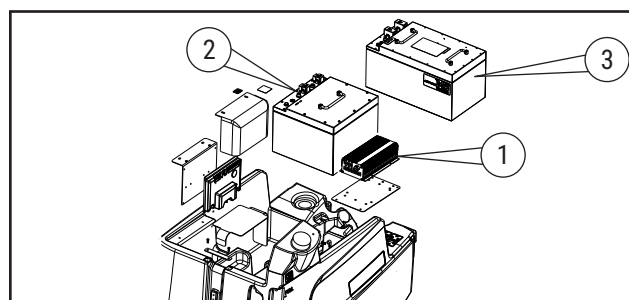

## EXTERNAL CHARGER

FIG.22

To charge the batteries from a fixed station, use an external charger with a 24V output and the current rating specific to the battery type, connected to a mains supply with voltage and frequency compatible with the country where the machine is used.

Pay attention to the charger settings according to the type of battery installed on the machine (for example: lead-acid, GEL, AGM, or "EKT" lithium batteries).

### Example of external charger for lead-acid, gel, and agm batteries

Plug into the mains socket

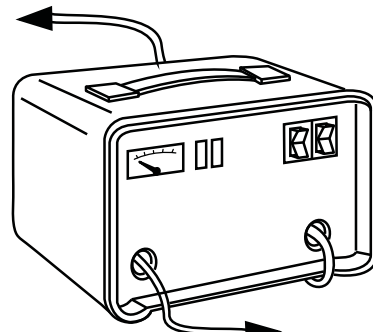

Plug into the socket on the battery cable

### Example of external charger for EKT lithium batteries

Battery charger 24V - 50A for lithium battery "EKT 25.6V - 150Ah"

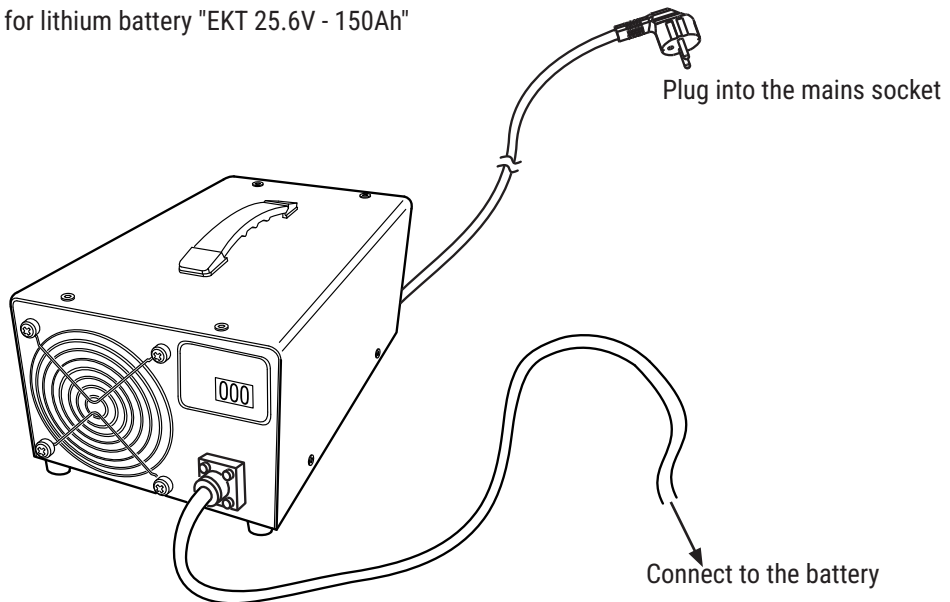

Plug into the mains socket

Connect to the battery

# CONTROL UNIT ALARMS

## Diagnostics of control unit alarms

In the event of an anomaly or malfunction of the machine, the control unit will display the alarm on the display as shown in the following image:

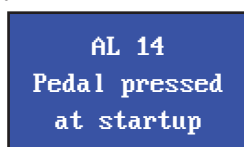

FUNCTION alarm list	
Alarm	
AL 1	Brush amperometric error
AL 2	Aspirator amperometric error
AL 4	Brush overtemperature
AL 5	Vacuum/brush control overtemperature
AL 6	Water pump overcurrent
AL 7	Actuator error
AL 8	Motor current initial threshold error
AL 10	Missing marking
AL 12	Microcontroller slowdown

TRACTION alarm list	
Alarm	
AL 13	Accelerator pedal not connected or broken
AL 14	Pedal pressed at startup
AL 15	Traction motor temperature alarm
AL 17	Traction motor overcurrent
AL 18	Traction motor delay current alarm

GENERAL alarm list	
Alarm	
AL 3	Power supply undervoltage
AL 11	Dirty water tank (recovery) full
AL 16	Clean water tank (solution) empty
AL 20	EEPROM error
AL 21	Key error
AL 22	Main relay faulty
AL 23	Battery overvoltage
AL 25	Failure to communicate with power board
AL 26	Operator not seated
AL 27	Failure to communicate BMS with "EKT" lithium battery
AL 28	Encoder error
AL 29	Damaged brake
AL 30	Tilted machine alarm
AL 31	Failure to communicate with gyroscope
AL 32	"EKT" lithium battery fault



**ATTENTION!**

**FOR INFORMATION RELATIVE TO THE ALARMS, CONTACT THE ASSISTANCE SERVICE**

# ELECTRICAL SYSTEM - WIRING DIAGRAM

FIG.23  
(1/3)

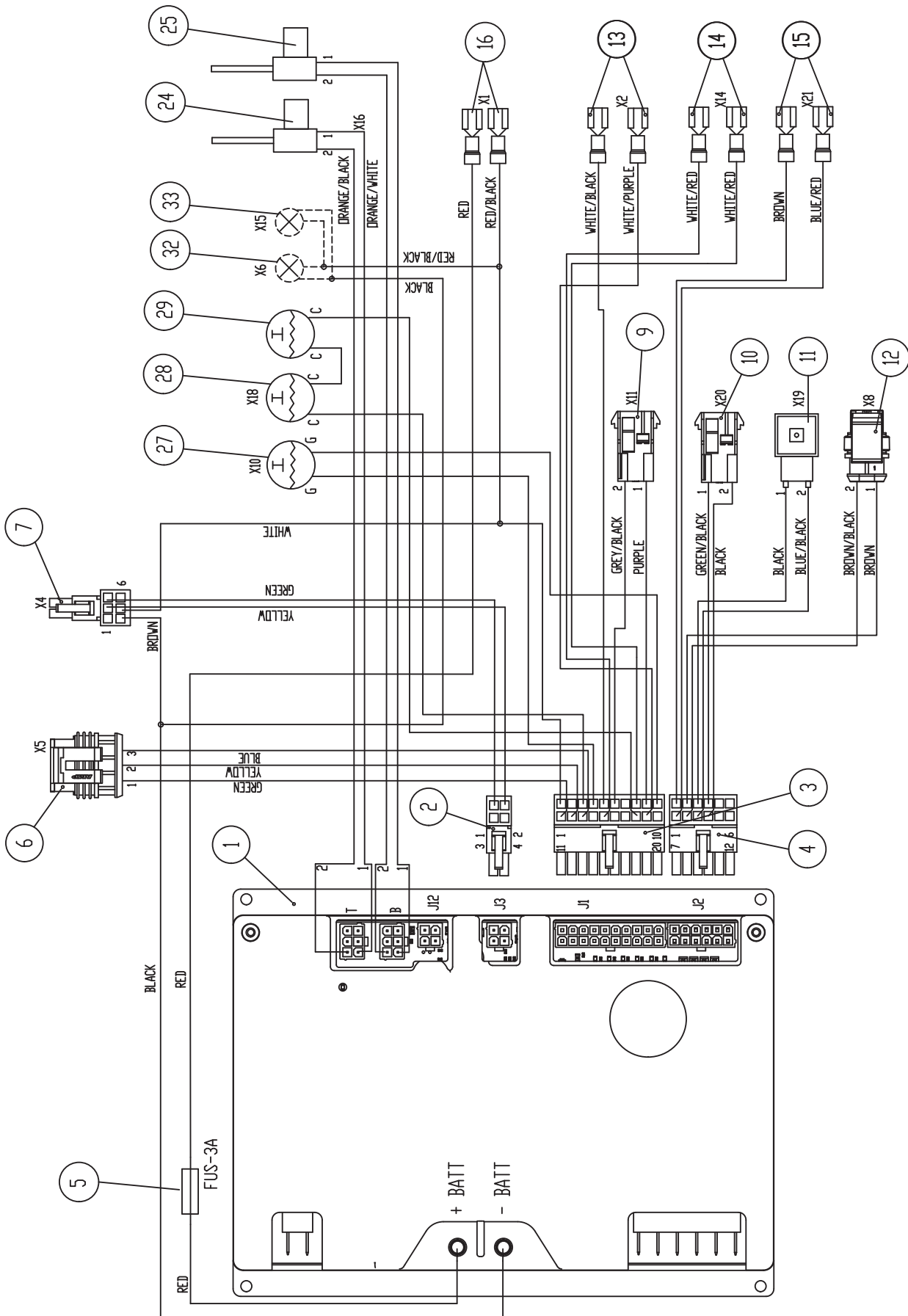

# ELECTRICAL SYSTEM - WIRING DIAGRAM

FIG.23  
(2/3)

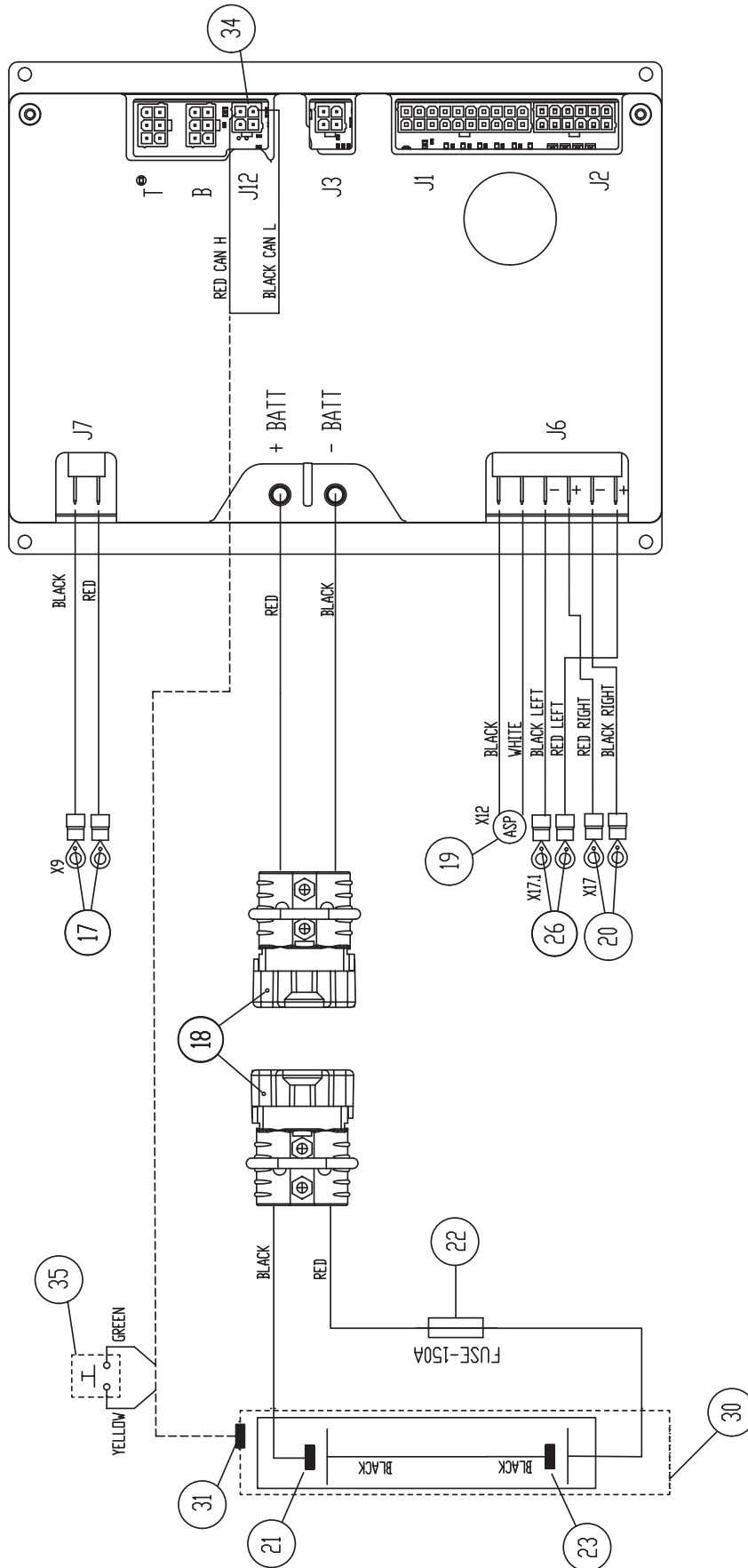

### Descrizione schema elettrico

1. Electronic function check
2. J3 keyboard connector
3. J1 function connector
4. J2 function connector
5. fuse 3A
6. X5 accelerator pedal
7. X4 dashboard controls
8. charger
9. X11 recovery tank float
10. X20 water pump (optional)
11. X19 water solenoid valve
12. X8 electromagnetic brake
13. X2 reverse button
14. X14 seat micro
15. X21 detergent pump (optional)
16. X1 ignition key
17. X9 traction motor
18. battery connectors
19. X12 vacuum motor
20. X17 right brush or single brush motor
21. battery 1
22. fuse 150A
23. battery 2
24. X16 squeegee actuator
25. brush actuator
26. X17.1 left brush motor
27. X10 traction motor thermal
28. X18 brush motor thermal
29. brush motor thermal
30. "EKT" lithium battery (optional)
31. can cable (optional)
32. X6 LED light
33. X15 flashing light
34. J12 can H (pin 1) red / can L (pin 2) black [optional]
35. "EKT" lithium battery switch

## PERIODIC CONTROL AND MAINTENANCE OPERATIONS AND SAFETY CHECKS

The machine must be inspected by a qualified technician to check its safety condition and for any potential damage or defects in the following cases:

- Before commissioning.
- After modifications and repairs.
- Periodically, as per "Control and maintenance operations table".

Every six months check the efficiency of the safety devices; the inspection must be carried out by specialist and qualified personnel. To ensure the efficiency of the safety devices, every 5 years the machine must be serviced by an authorised workshop.

The person responsible for managing the machine must carry out an annual check on the status of the machine. During this inspection, the technician must verify whether the machine still complies with the prescribed technical safety requirements. After the inspection, a test/inspection label must be applied to the machine.

Control and maintenance operations table		carried out after number of hours:		
		8	40	200
1	Check batteries	✓		
2	Clean the recovery tank and filter	✓		
3	Check the clean water tank filter	✓		
4	Check the cleanliness of the drain, suction and scrubber pipes	✓		
5	Check the cleanliness of the waste collection basket, located inside the recovery tank	✓		
6	Check the status of the brushes		✓	
7	Check the status of the squeegee rubber blades		✓	
8	Check the solenoid valve for water supply (washing solution)		✓	
19	Check the status of the carbon brushes of each motor			✓
10	If there is any optional equipment, check its cleanliness and operation	✓		

# TROUBLESHOOTING

1/2

Problem	Cause	Solution
The squeegee does not dry	Worn squeegee rubber blades	Replace the rubber blades
	Squeegee clogged	Clean the squeegee
	A foreign object has become wedged in the squeegee	Remove the foreign object
	Vacuum hose clogged	Clean the hose
	Squeegee poorly adjusted	Adjust the inclination
	Water drain hose cap open	Close tightly
	Vacuum motor blown	Replace the motor
	Vacuum motor brushes worn	Replace the brushes
	Floor squeegee not lowered at start-up, actuator defective.	Replace the actuator
	Recovery tank cover gaskets, damaged	Replace gaskets
The detergent solution does not come down evenly on the brushes.	Water supply hoses on the brushes, clogged	Clean piping
The detergent solution does not come down or only a small amount comes out on the brushes	Water supply hoses on the brushes, clogged.	Clean piping
	Water supply hoses on the brushes, crushed.	Restore hose or replace
	Water filter (solution) clogged	Clean filter
	Water filter (solution) not perfectly closed	Check the perfect tightness of the water filter
	Shut-off solenoid valve blocked	Check operation of the solenoid valve
	No water in the tank	Fill the water tank
	Water pump (optional)	Check water pump operation
The machine does not clean well	Brushes badly worn	Replace brushes
	Brushes unsuitable for the type of floor	Use suitable brushes
	Detergent not suitable	Replace detergent
	High operating speed	Decrease speed
the machine does not start	The main ignition key has not been inserted	Insert key and turn clockwise
	The batteries are low	Check the charge level and charge them, if necessary
	Blown fuse	Check and replace the fuse, if necessary <b>Read NOTE!</b>
	Safety micro-switch under the seat, broken	Replace the micro-switch
	On-board charger anti-pull relay, faulty	Replace on-board charger
	Battery connection plug not inserted	Connect plug
The machine does not start or it stops suddenly	Batteries disconnected	Connect batteries
	Batteries low	Charge the batteries
	Motors under enough stress to trip the thermal magnetic protection. The fault will be displayed on the screen.	Wait for about a minute and then repeat the start-up procedure.
	The operator got up and the micro under the seat has cut off the power to the system.	Sit and press the accelerator pedal
	Anomaly, alarm on the display	see alarm list

< continued on the next page >

**NOTE!**

**NEVER USE FUSES OF A HIGHER VALUE, YOU RISK CAUSING DAMAGE TO THE SYSTEM. IF THE FUSES BLOW REPEATEDLY, THIS MEANS THE MACHINE HAS A DEFECT. CONTACT AN AUTHORISED SERVICE CENTRE.**

# TROUBLESHOOTING

2/2

Problem	Cause	Solution
The machine does not move forward or in reverse.	Accelerator pedal connector disconnected	Reconnect connector
	Safety micro-switch under the seat, broken	Replace micro-switch
	Damaged traction electric motor wheel or worn carbon brushes.	Replace electric wheel or carbon brushes
	Traction motor thermal protection. The fault will be displayed on the screen	Wait for motor cooling
	Electromagnetic brake disengaged or faulty	Engage the electromagnetic brake or replace it.
The vacuum motor switches off and does not start	Motor connection, motor damaged.	Check motor and the connections or replace motor
	Reverse gear engaged	Disengage reverse gear
The machine does not move	Electromagnetic brake on front wheel disengaged, faulty, or not powered.	Check operation of electromagnetic brake or electric wheel
Water leak when machine is stopped	Feed tube broken	Replace
The brushes do not lift or lower	Brush motor thermal protection	Wait for motor cooling
	The brushes do not lower when the solution tank is empty	Fill the tank
	Batteries discharged by 80%	Recharge batteries
	The brush actuator does not receive power	Check
	Brush actuator broken	Replace
	Actuator micro faulty	Replace
	Control unit	Check control unit or replace if faulty
the squeegee does not lift or lower	Recovery tank full	Empty the tank
	Reverse gear engaged	Disengage reverse gear
	Batteries discharged by 90%	Charge the batteries
	The squeegee actuator does not receive current. The fault will be displayed on the screen	Check
	Squeegee actuator, broken	Replace
	Actuator micro faulty	Replace
	Control unit	Check control unit or replace if faulty

## SAFETY INFORMATION

### **Cleaning**

In the cleaning and washing operations of the machine, aggressive detergents, acids, etc., must be used with caution. Follow the instructions of the detergent manufacturer and, if required, use protective clothing (overalls, gloves, goggles, etc.). See relevant EC Machinery Directive.



### **Explosive atmosphere**

The machine is not built to work in environments with the possibility of existing gas, dust or fumes. As such, using it in explosive atmospheres is PROHIBITED.

### **Disposal of toxic substances**

To dispose of the collected material, machine filters and exhausted material such as batteries, motor oil, etc., follow the laws in force regarding their disposal and treatment.

## MACHINE DEMOLITION

 The machine must be brought to a licensed collector who will see to disposing of it properly. In particular oils, filters and batteries.  
 The ABS and metal parts can be recycled as secondary raw materials. The rubber hoses and gaskets, as well as the plastic and common fibreglass and plastic must be separately conferred to municipal cleaning companies.

 The packaging of the machine is composed of recyclable material. Dispose of it by bringing it to special recycling centres.



